

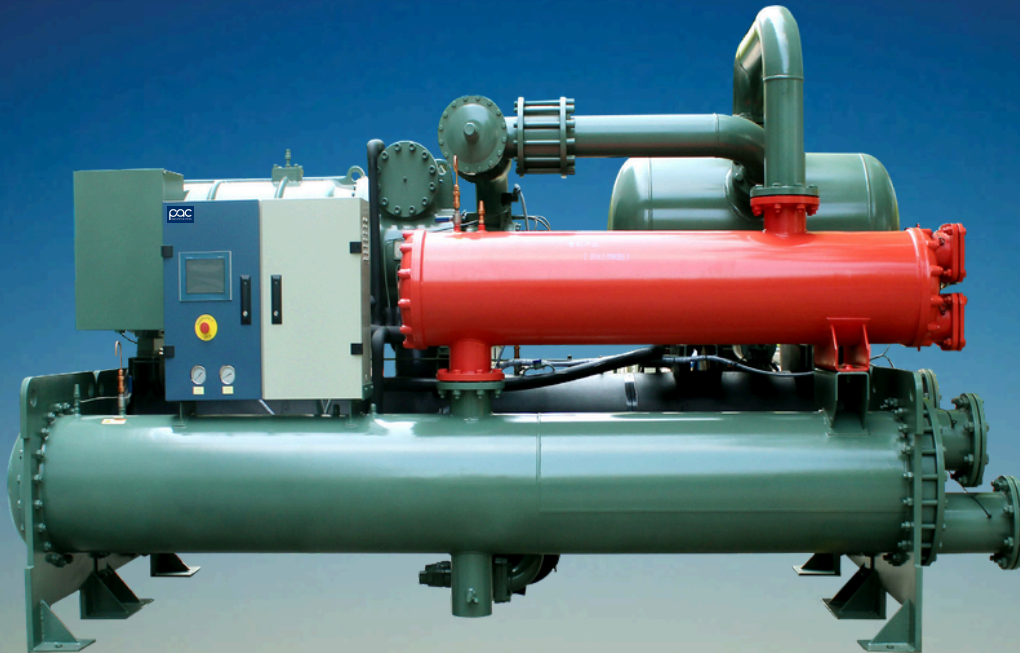

PAC Low Temperature / Glycol Chiller



Customized Design

The chiller can be designed according to the dimension of the machine room, and it can be delivered to the site by CKD (completely knock down) or SKD(semi knock down) or the whole unit. Different power supply are available according to different countries and regions ,such as high-voltage non-standard chiller .

Heat Recovery Unit (optional)

Own a heat recovery patent.

Waste heat generated in the refrigeration process is recovered by H.Stars patented heat recovery unit to provide free hot water up to 55°C. Boiler replacement to save operating cost.

Professional Design

According to user's requirements, H.Stars provides professional advice and selects the most suitable equipment which fits perfectly for each project. Different materials of heat exchange will be recommended to avoid corrosion and leakage according to user's refrigeration medium used in the project.

Energy-saving Design (optional)

The variable frequency drive technology greatly improves the Partial load energy efficiency of the chiller ;

Evaporative cooling technology with function of high heat exchange efficiency, low investment and save water.

Intelligent Operation

Adopting Microcomputer controller, precise control, automatic loading and unloading with multiple functions such as time setting, fault record remote or central monitor. PLC is available for option.

Precision Protection

The Chiller electrical protection system includes: reverse protection, phase loss protection, compressor and fan overcurrent protection, low temperature protection, high and low voltage protection, water flow protection, etc.

Water Temperature

High temperature type: chilled water outlet 0°C;

Medium and low temperature type: chilled water outlet -20°C;

Ultra-low temperature type: chilled water outlet -35°C.

Display function

The chiller control display can collect various states data of the chiller, and can display operation time, compressor output, inlet and outlet water temperature, and operating status.

Model Nomenclature

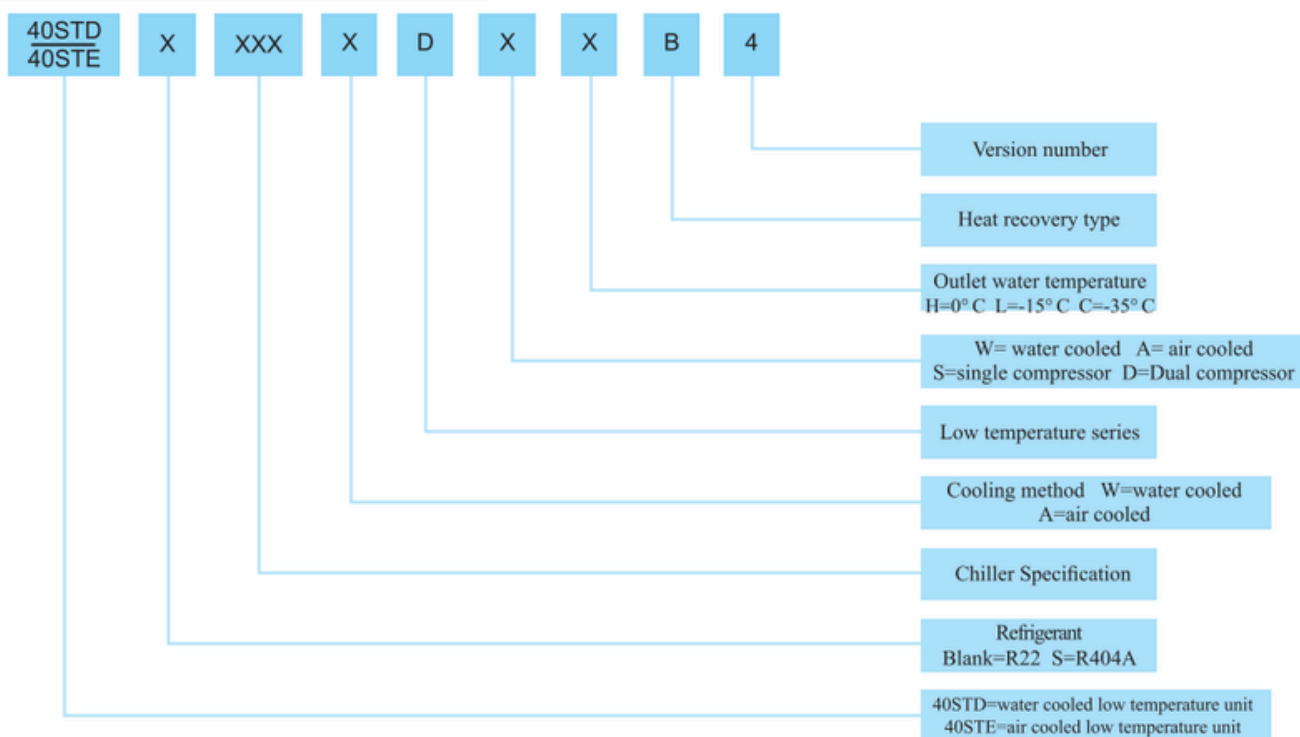

Air cooled low temperature chiller

Standard configuration

Compressor	Hanbell Screw compressor
Evaporator	Self-made high efficiency evaporator
Condenser	Self-made high efficiency fin type condenser
Fan	Axial fan
Controller	Siemens PLC programmable controller
Economizer	Self-made high efficiency plate heat exchanger
Throttle device	Thermal / electronic expansion valve
Startup mode	Star delta starting
Power supply	380V-3N-50Hz/460V-3N-60Hz
Insulation material	Anti-corrosion, Waterproof, Mesh insulation
Oil Paint	High-strength matt paint
Water pipe connection	Flange

40STE series air-cooled screw type low temperature chiller adopts high efficiency dual screw compressors, equipped with self-made high-efficiency shell and tube heat exchangers and fin type heat exchangers. Heat recovery unit can be configured based on customer needs. Suitable for industry processes



in pharmaceutical, chemical, electronics, food processing industries etc. The unit has 24 standard specifications, cooling capacity range: 60kw~340kw, chilled water outlet temperature: 5 °C ~ -35 °C.

Water cooled low temperature chiller

Standard configuration

Compressor	Hanbell Screw compressor
Evaporator	Self-made high efficiency evaporator
Condenser	Self-made high efficiency condenser
Controller	Siemens PLC programmable controller
Economizer	Self-made high efficiency plate heat exchanger
Throttle device	Thermal / electronic expansion valve
Startup mode	Star delta starting
Power supply	380V-3N-50Hz/460V-3N-60Hz
Insulation material	Anti-corrosion, Waterproof, Mesh insulation
Oil Paint	High-strength matt paint
Water pipe connection	Flange

40STD series water-cooled screw type low temperature chiller adopts high efficiency dual screw compressors, equipped with self-made high-efficiency shell and tube heat exchangers. Heat recovery unit can be configured based on customer needs. Suitable in pharmaceutical, chemical, electronics, food processing, etc.



According to different water outlet temperature, it can be divided into high temperature type, low temperature type and ultra low temperature type. The cooling capacity range is 70kw~2369kw, chilled water outlet temperature: 5 °C ~ -35 °C .

Chiller Main Components

Compressor

The compressor adopts a well known brand screw compressor with a 5:6 screw rotor design, which is 20%-30% more efficient than a typical compressor. Applicable to environmentally friendly refrigerant like R134A, R407C, R404A with compressor-specific motor, low failure rate, stable and reliable operation, no fault operation time: 50000-80000 hours. The products have obtained two international quality certifications of ISO9001 and ISO9002 and multinational patents in Europe and America.



Compressor

Shell and tube evaporator / condenser

The condenser and evaporator are the most important components of the chiller. The quality and manufacturing process determine the heat exchange efficiency and lifespan of the unit. It also represents whether a manufacturer has core technology and intellectual property. H.Stars heat exchanger is self-manufactured with design qualification and pressure vessel production qualification in strict accordance with international standards to ensure product safety and reliability.



Shell and tube evaporator



Shell and tube condenser

Fin condenser

High efficiency heat exchanger

Intelligent design to reduce fan energy consumption while achieving maximum heat transfer. Intelligent copper tube design reduces the pressure drop in the coil (the maximum temperature drop is 0.63K when the refrigerant is R404).



High efficiency heat exchanger

Axial Fan

Dedicated low-energy fan, intelligent fan nozzle design maximizes air gas flow and noise reduction, stable with long lifespan; motor is with waterproof and dustproof function: IP54; insulation grade: F.



Axial Fan

Chiller Main Components

HMI (Human Machine Interface)

10" / 8" true color touch screen

Support USB upgrade.

Easy operation and intuitive dynamic operation.

Displays control center greatly improves efficiency to provide monitoring, data logging, security protection and convenient operation. The control center has a color liquid crystal display (LCD) and a touch panel.

Simply press a single button to display a series of technical data and color maps of the corresponding components, making the chiller clearer and easier to operate.



Full color display screen

Precise water temperature control

The control system monitors the change of the chilled water temperature, senses the past and present water temperature conditions, temperature change rate, and precisely adjusts the chiller according to the monitored conditions to operate according to the set value.

The chiller password is divided into multiple levels of passwords, providing the operator with a secure access password to prevent unauthorized changes to the settings.

Network of multiple units

Standard MODBUS interface, compatible with various engineering building management systems.

Innovative device LAN interface enables multiple devices to be connected into a network to optimize device operation and extend devices lifespan.

R_LAN address knob dial, which can set the address of different modules at the site.

Engineering electric cabinet can combine in the unit, which

greatly reduces the cost on site.

The wire controller can achieve non-stop mode switching.

Multiple language display, directly show the unit operation, fault conditions, built-in operating instructions, to facilitate the use of the unit.

Optional hydraulic module control available.

Control Center

Adopts advanced, highly integrated single-chip microcomputer control, greatly improves the anti-interference ability of the system.

The HMI directly displays the fault content to cooperate with the simple operation interface to timely feedback various maintenance information. Three-phase voltage and current are displayed in real time.

The control adopts a combination of protection, real-time control and alarm to protect the safe operation of the unit.

The control center can be connected to the network for control, group control and single unit control switching.

It can be connected to the Modbus host computer system, enabling users to monitor the running status of the unit in real time at all aspects.

Access to cloud service systems.



Integrated controller

Standard controller

Function

Parameter	Water-cooled and air-cooled chiller	Authority	Setting range
Setting mode	Cooling	User	Cooling
chiller setting temperature	12.0°C	User	Lowest cooling limit ~ 30.0
* chilled water loading deviation	2.0°C	User	0.5 ~ 10.0
* chilled water unloading deviation	2.0°C	User	0.5 ~ 10.0
* 1#Compressor usage setting	Enable	User	Disable、Enable
* 2#Compressor usage setting	Enable	User	Disable、Enable
Timed usage setting	Disable	User	Disable、Enable
Remote-monitoring swift between cooling and heating	/	User	Disable、Enable

Fault display

Fault name	Testing condition	Alarm action	Fault resolution
External alarm	Power on detection	Shutdown unit	Check external alarm switch signal
Overloading chilled water pump, cooling water pump, fan ,compressor	Power on detection	Shutdown unit	Check corresponding overload switch signal
Lack of chilled or cooling water	pump turned on, check water flow	Shutdown unit	Check corresponding water flow switch signal
System power fault	Power on detection	Shutdown unit	Check corresponding system power fault switch signal
Temperature、 pressure sensor fault	Power on detection	Shutdown unit	Check corresponding probe
System outlet water temperature or pressure over high or low	Power on detection	Shutdown unit	Check corresponding normal sensor data

PLC

Function

Parameter	Water-cooled and air-cooled chiller	Authority	Setting range
Setting mode	Cooling	User	Cooling
Chilled Water setting temperature	12.0°C	User	Lowest cooling limit ~ 30.0
Selection of targeted	Supply water	User	Supply water/return water
* 1#Compressor usage setting	Enable	User	Disable、Enable
* 2#Compressor usage setting	Enable	User	Disable、Enable
Timed usage setting	Disable	User	Disable、Enable
external circulation temperature set	10°C	User	-30 ~ 100
IP address setting #(1)	/	User	Random IP
MODBUS Parameter setting #(2)	/	User	/
Compressor load limit	/	User	50%、75%、100%；66%、100%

Fault display

Fault name	Testing condition	Alarm action	Fault resolution
External alarm	Power on detection	Shutdown unit	Check external alarm switch signal
Overloading chilled water pump, cooling water pump, fan ,compressor	Power on detection	Shutdown unit	Check corresponding overload switch signal
Lack of chilled or cooling water	pump turned on, check water flow	Shutdown unit	Check corresponding water flow switch signal
Phase protection	Power on detection	Shutdown unit	Check (phase protection) switch signal
Overloading of external circulation or heat recovery pump	Power on detection	Only shutdown the water pump	Check corresponding circulation pump overload switch signal
Inadequate water flow for external circulation or heat recovery	Pump turned on, water flow installed	Only shutdown the water pump	Check corresponding water flow switch signal
Oil level、 Ice-proof、 Expansion valve and compressor protection	Chiller operating testing	Shutdown unit	Check corresponding switching valve
Pressure, temperature too high/low failure temperature	Power on detection	Shutdown unit	Check corresponding normal sensor data
Pressure, temperature sensor failure	Power on detection	Shutdown unit	Check corresponding (sensor)

Evaporative chiller



Evaporative indoor chiller

40STD series evaporative industrial chiller is a new developed high efficiency product based on standard industrial chiller of PAC Corporation which adopts high efficiency flooded type evaporator and evaporative condenser with further improvement of efficiency. The evaporative condenser uses less water and is especially suitable for dry areas. Widely applicable for commercial buildings, industrial, refrigeration and other fields which needs electricity saving and limited water.

Customized chiller available for high voltage , explosion-proof, anti-corrosion and other special products as per user's request.



Outdoor unit of evaporative condenser

The evaporative chiller outdoor unit is designed with the optimized heat transfer principle, and uses the water evaporation on the outer surface of the tube to cool and condense the working medium inside the tube through mass transfer and heat transfer, meanwhile combine with the cooling device, the average flow rate compared with the water condenser ,increases by 15%-18%.The overall performance is increased by 25% and the equipment size is more compact and input power will be less to greatly reduce the energy consumption and operating costs of the chiller.

The product has eight features: excellent heat exchange performance, easy to clean ,convenient installation, low failure rate, easy maintenance, low operating cost, energy saving, green to environment, compact size and low investment.

Integrated chiller

For the chiller engineering installation, it is required to build a machine room with short construction period and heavy tasks. H.Stars Group has developed, designed and manufactured a series of integrated chiller with professional experience in chiller system and engineering technology installation. At the same time, according to the needs of different engineering installations, the integrated chiller can be designed with different configurations and different dimensions . The chiller integrates with water pump, water tank , various valves , control devices and pipeline into an integrated system , which is very easy to install and control, not only to reduce the engineering labor cost by combining engineering parts ,but also to control all in one unit to avoid multiple control boxes to improve chiller control system stability and make the whole unit more compact in size.



Heat recovery

The heat recovery technology is to recover part or all of the same amount of heat energy from the chiller while it is cooling, to provide customers with a large amount of free hot water at 45~55 °C, suitable for electronics, chemical, pharmaceutical, food processing industries. Environmental protection and energy saving.



Heat recovery patent number: ZL03223588.7

Schematic diagram of heat recovery unit

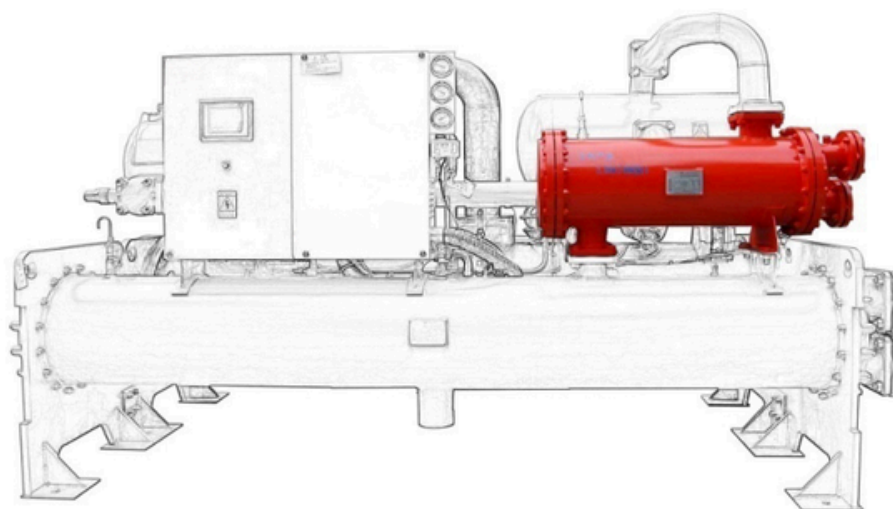

Heat recovery

PAC Corporation has been engaged in R&D of heat recovery technology and application, accumulated a lot of experience in thermal energy recycling, and has a national patent for heat recovery. Provide customers with free hot water during the project , cost and energy saving. It can reduce the heat pollution caused by condensation heat to the environment, and reduce the running cost and noise of the cooling tower.

Brief introduction of heat recovery technology

The heat recovery technology is an air-conditioning energy-saving patented invention. The principle is that when the unit is cooled, the heat originally discharged into the atmosphere can be recovered and converted into hot water, which can be used for living hot water, process heating. During heat recovery process, only the circulating

water pump need to be installed, a large amount of free hot water is provided. At the same time, the cooling capacity of the unit is increased by about 5%, which is suitable for industrial production processes and commercial places with large demand.

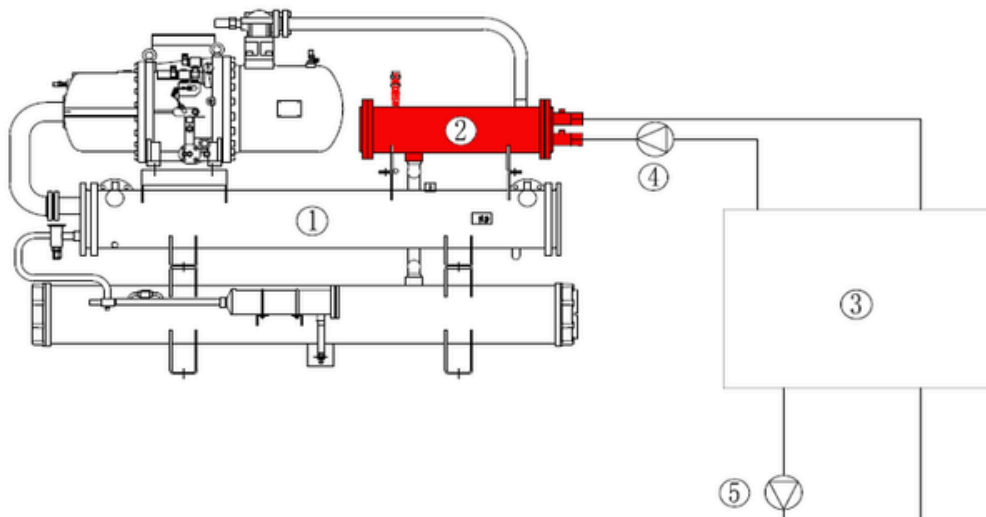

Description of heat recovery system

1. Heat recovery chiller unit
2. Heat recovery unit
3. Hot water storage tank
4. Heat recovery circulation water pump
5. Hot water distribution water pump

Heat recovery selection reference table (hot water temperature : 50-55°C)

Model	30% Heat recovery		100% Heat recovery	
	Heat recovery model	Heat recovery capacity (kW)	Heat recovery model	Heat recovery capacity (kW)
40STE-140ADSL4	UHR009A	29	UHR030A	97
40STE-410ADSL4	UHR028A	88	UHR092A	293
40STE-460ADDL4	UHR031B	100	UHR104B	333
40STE-740ADDL4	UHR050B	170	UHR168B	566
40STD-550WDS(L)(C)4	UHR039A	124	UHR130A	413
40STD-930WDS(L)(C)4	UHR068A	215	UHR225A	717
40STD-1520WDS(L)(C)4	UHR108A	355	UHR360A	1183
40STD-680WDD(L)(C)4	UHR045B	152	UHR075A*2	507
40STD-1660WDD(L)(C)4	UHR063A*2	382	UHR210A*2	1273
40STD-3040WDD(L)(C)4	UHR108A*2	711	UHR360A*2	2370
40STD-4560WDT(L)(C)4	UHR108A*3	1067	UHR360A*3	3557

Heat Exchanger Tube

Condenser heat exchange tube

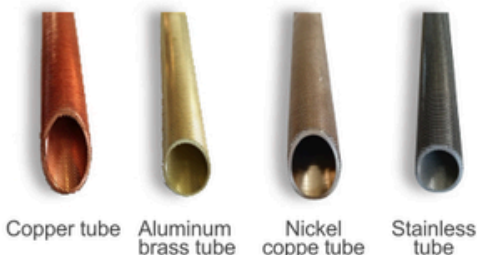

Condenser heat exchange tube specification sheet

Heat exchange tube material	Copper Tube	Aluminum Brass Tube	Nickel Copper Tube	Stainless Tube
Tube thickness option 1 (mm)	1	1.2	1	1
Tube thickness option 2 (mm)	1.1	1.3	1.1	1.15
Tube thickness option 3 (mm)	1.2	1.4	1.2	1.2
Tube thickness option 4 (mm)	1.3	1.5	1.3	1.35
Suitable for water quality	Standard non-corrosive neutral water	seawater	Alkaline water	Acid water

Evaporator Heat Exchanger Tube



Evaporator heat exchange tube specification sheet

Heat exchange tube material	Copper Tube	Aluminum Brass Tube	Nickel Copper Tube	Stainless Tube
Tube thickness option 1 (mm)	1	1.2	1	1
Tube thickness option 2 (mm)	1.1	1.3	1.1	1.15
Tube thickness option 3 (mm)	1.2	1.4	1.2	1.2
Tube thickness option 4 (mm)	1.3	1.5	1.3	1.35
Suitable for water quality	Standard non-corrosive neutral water	seawater	Alkaline water	Acid water

Important Notice:

Heat exchanger is the key components of the chiller unit, its manufacturing technology directly affects the quality of the product. Also, the heat exchange tube, which is the only component of the heat exchanger in contact with the ambient, closely affects the life of the

unit. The thickness and material of the heat exchange tube are very important. Customers can choose the suitable material and thickness of heat exchanger tube according to the air and water quality.

Fin heat exchanger

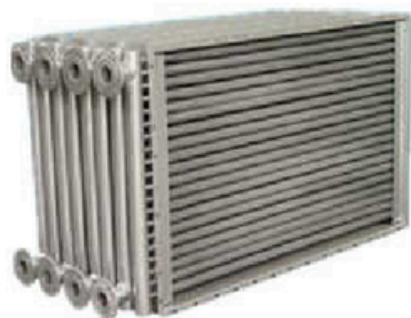

Aluminum fin heat exchanger



Brass fin heat exchanger



Stainless Steel heat exchanger

Optional Parts (Five)

VFD low temperature chiller

VFD low-temperature chiller is based on the existing chiller but adopting VFD on the compressor, to achieve a variable frequency operation system on the chiller. It is a double-

efficient unit with full load Coefficient Of Performance (COP) and Integrated Part Load Value (IPLV).

High efficiency and energy-saving

Adopt international brand variable frequency drive technology to improve integrated part load value (IPLV) up to 8.

Stability and reliability

The VFD low temperature chiller with simple compressor structure, adopts the motor speed to control the output load to achieve true stepless control to improve compressor reliability. Refrigerant suction cooling motor at low temperature, more stable: Low starting current.

Small starting current

VFD screw chiller with soft starter, reducing the impact of starting current; The VFD has its own DC reactor to minimize harmonic interference; Optional low-harmonic filter. VFD input power meets the IEEE-519 specification for harmonic distortion with harmonic filter over-temperature protection and capacitance switching.

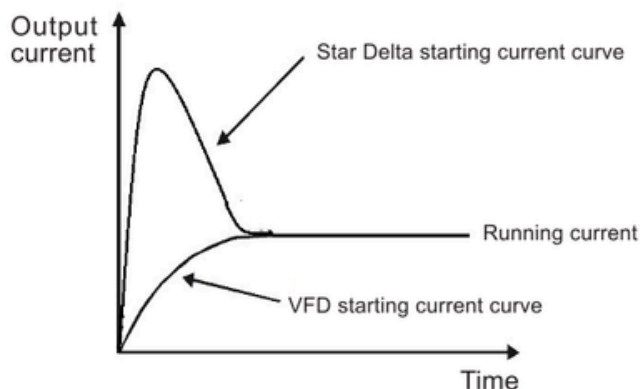

Accurate temperature control

The outlet water temperature can be controlled precisely within $\pm 0.3^{\circ}\text{C}$ to meet high precision temperature control requirement.

VFD Diagram

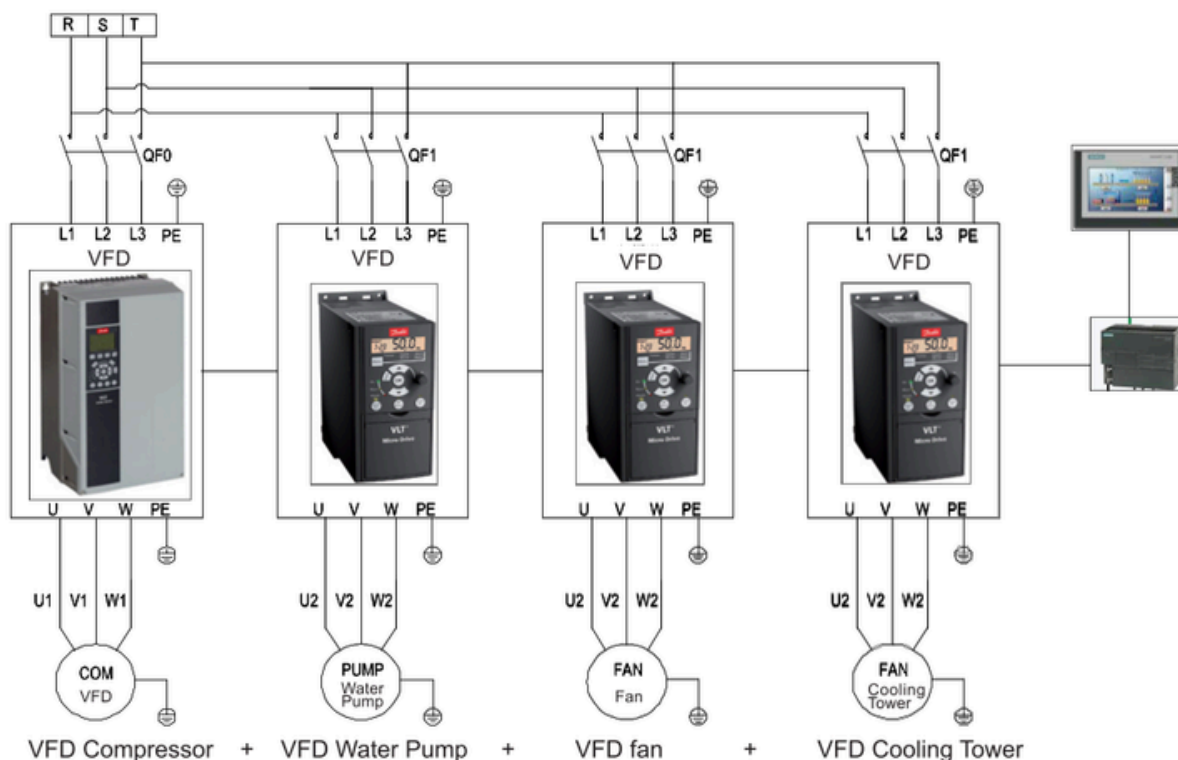

Winter energy-saving device (dry cooler)

In the transitional season and winter, the outdoor ambient temperature is lower than the process water temperature, taking advantage of the cold air outside to cool the process water without turning on the compressor. The dry cooler uses this principle to achieve the real non-compressor cooler. When the ambient temperature is lower than the process water temperature, the process water run

through the dry cooler heat exchange tube. The fan is used to control the flow of outside cold air to cool the process water, and to ensure that the process water temperature meets the set requirements. It meets the requirements and saves 90% energy.



Cloud service (remote monitoring)

Central A/C cloud service system



Cloud service value:

- Remote control adjustment
- Remote monitoring
- Remote upgrade
- Fault warning
- Remote diagnosis
- Product distribution management
- Historical data analysis

Air Cooled Low Temperature Chiller Parameter / 50Hz

PAC Low Temperature / Glycol Chiller

Air-cooled low temperature chiller parameters

Refrigerant: R22 Power supply: 380V-3N-50Hz

Model	Nominal cooling capacity		Compressor Input Power KW	Capacity control %	Refrigerant charge kg	Condenser	Evaporator				Axial Fan		Operating sound level dB(A)	Shipping weight kg	Operating weight kg
	kW	USRT					condenser Inlet outlet pipe diameter in	Chilled Water flow m ³ /h	Water Side Max. Pressure Mpa	Water pressure dropKPa	Air flow×1000 m ³ /h	Power kW × number			
40STE-140ADSL4	55.4	15.8	32.6	0, 66, 100	30	Copper tube with corrugated aluminum fins	2-1/2"	10.1	1	28	40.2	2.0×2	68	1260	1370
40STE-200ADSL4	78.2	22.2	45.0	0, 50, 75, 100	42		3"	14.2	1	55	57	1.2×4	68	1900	2080
40STE-260ADSL4	104.7	29.8	58.9	0, 50, 75, 100	56		3"	19.1	1	64	80	2.0×4	72	2700	2920
40STE-300ADSL4	123.5	35.1	66.8	0, 50, 75, 100	68		3"	22.5	1	66	80	2.0×4	72	2780	3020
40STE-340ADSL4	145.3	41.3	77.5	0, 50, 75, 100	80		4"	26.4	1	42	85	1.2×6	72	3220	3380
40STE-370ADSL4	156.5	44.5	84.0	0, 50, 75, 100	86		4"	28.5	1	54	121	2.0×6	72	3240	3620
40STE-410ADSL4	170.1	48.4	92.6	0, 50, 75, 100	95		4"	31.0	1	44	121	2.0×6	72	3500	3880
40STE-460ADSL4	194.4	55.3	107.8	0,25,37.5,50,62.5,75,87.5,100	115		4"	35.4	1	55	114	1.2×8	75	4780	4950
40STE-520ADSL4	209.4	59.5	117.8		124		4"	38.1	1	65	161	2.0×8	75	4850	5130
40STE-600ADSL4	247.0	70.2	133.6		135		4"	44.9	1	54	161	2.0×8	75	5360	5580
40STE-680ADSL4	290.6	82.6	155.0		161		4"	52.9	1	65	170	1.6×12	75	5660	6100
40STE-740ADSL4	313.0	89.0	168		175		4"	57.0	1	54	241	2.0×12	75	5720	6040

Note:

- Nominal cooling capacity benchmark: air dry / wet bulb temperature 35 °C / 24 °C, chilled water inlet and outlet water temperature -10 °C / -15 °C; fouling factor 0.018 m² · °C / kW;
- Chilled water temperature range: -15 °C ~ 5 °C;
- Ambient temperature range: 5 °C ~ 43 °C;
- Specifications and dimensions are subject to improvement without notice.

Air-cooled low temperature chiller technical parameters

Refrigerant: R404A Power supply: 380V-3N-50Hz

Model	Nominal cooling capacity		Compressor Input Power KW	Capacity control %	Refrigerant charge kg	Condenser	Evaporator				Axial Fan		Operating sound level dB(A)	Shipping weight kg	Operating weight kg
	kW	USRT					condenser Inlet outlet pipe diameter in	Chilled Water flow m ³ /h	Water Side Max. Pressure Mpa	Water pressure dropKPa	Air flow × 1000 m ³ /h	Power kW × number			
40STE-S140ADSL4	55.6	15.8	40.8	0%, 66%, 100%	30	Copper tube with corrugated aluminum fins	2-1/2"	10.1	1	28	40.2	2.0×2	68	1260	1370
40STE-S200ADSL4	78.4	22.3	56.9	0%, 50%, 75%, 100%	42		3"	14.3	1	55	57	1.2×4	68	1900	2080
40STE-S260ADSL4	104.8	29.8	75.1	0%, 50%, 75%, 100%	56		3"	19.1	1	64	80	2.0×4	72	2700	2920
40STE-S300ADSL4	124.0	35.3	87.7	0%, 50%, 75%, 100%	68		3"	22.6	1	66	80	2.0×4	72	2780	3020
40STE-S340ADSL4	145.6	41.4	101.7	0%, 50%, 75%, 100%	80		4"	26.5	1	42	85	1.2×6	72	3220	3380
40STE-S370ADSL4	156.8	44.6	110.4	0%, 50%, 75%, 100%	86		4"	28.5	1	54	121	2.0×6	72	3240	3620
40STE-S410ADSL4	170.4	48.5	119.6	0%, 50%, 75%, 100%	95		4"	31.0	1	44	121	2.0×6	72	3500	3880
40STE-S460ADSL4	195.2	55.5	138.4	0,25,37.5,50,62.5,75,87.5,100	115		4"	35.5	1	55	114	1.2×8	75	4780	4950
40STE-S520ADSL4	209.6	59.6	150.2		124		4"	38.1	1	65	161	2.0×8	75	4850	5130
40STE-S600ADSL4	248.0	70.5	175.4		135		4"	45.1	1	54	161	2.0×8	75	5360	5580
40STE-S680ADSL4	291.2	82.8	203.4		161		4"	53.0	1	65	170	1.6×12	75	5660	6100
40STE-S740ADSL4	313.6	89.2	220.8		175		4"	57.1	1	54	241	2.0×12	75	5720	6040

Note:

- Nominal cooling capacity benchmark: air dry / wet bulb temperature 35 °C / 24 °C, chilled water inlet and outlet water temperature -10 °C / -15 °C; fouling factor 0.018 m² · °C / kW;
- Chilled water temperature range: -15 °C ~ 5 °C
- Ambient temperature range: 5 °C ~ 43 °C
- Specifications and dimensions are subject to improvement without notice.

Air Cooled Low Temperature Chiller Parameter / 60Hz

PAC Low Temperature / Glycol Chiller

Air-cooled low temperature chiller parameters

Refrigerant: R22 Power supply: 460V-3N-60Hz

Model	Nominal cooling capacity		Compressor Input Power KW	Capacity control %	Refrigerant charge kg	Condenser	Evaporator				Axial Fan		Operating sound level dB(A)	Shipping weight kg	Operating weight kg
	kW	USRT					condenser Inlet outlet pipe diameter in	Chilled Water flow m3/h	Water Side Max. Pressure Mpa	Water pressure dropKPa	Air flow x1000 m3/h	Power kW x number			
40STE-140ADSL4	66	19	39	0, 66, 100	30	Copper tube with corrugated aluminum fins	2-1/2"	12	1	28	48	2.5x2	68	1386	1507
40STE-200ADSL4	94	27	54	0, 50, 75, 100	42		3"	17	1	55	68	1.5x4	68	2090	2288
40STE-260ADSL4	126	36	71	0, 50, 75, 100	56		3"	23	1	64	96	2.5x4	72	2970	3212
40STE-300ADSL4	148	42	80	0, 50, 75, 100	68		3"	27	1	66	96	2.5x4	72	3058	3322
40STE-340ADSL4	174	50	93	0, 50, 75, 100	80		4"	32	1	42	102	1.5x6	72	3542	3718
40STE-370ADSL4	188	53	101	0, 50, 75, 100	86		4"	34	1	54	145	2.5x6	72	3564	3982
40STE-410ADSL4	204	58	111	0, 50, 75, 100	95		4"	37	1	44	145	2.5x6	72	3850	4268
40STE-460ADDL4	233	66	129	0,25,37.5,50,62.5,75,87.5,100	115		4"	42	1	55	137	1.5x8	75	5258	5445
40STE-520ADDL4	251	71	141		124		4"	46	1	65	193	2.5x8	75	5335	5643
40STE-600ADDL4	296	84	160		135		4"	54	1	54	193	2.5x8	75	5896	6138
40STE-680ADDL4	349	99	186		161		4"	63	1	65	204	2.5x8	75	6226	6710
40STE-740ADDL4	376	107	202		175		4"	68	1	54	289	2.5x12	75	6292	6644

Note:

- Nominal cooling capacity benchmark: air dry / wet bulb temperature 35 °C / 24 °C, chilled water inlet and outlet water temperature -10 °C / -15 °C; fouling factor 0.018 m² · °C / kW;
- Chilled water temperature range: -15 °C ~ 5 °C;
- Ambient temperature range: 5 °C ~ 43 °C;
- Specifications and dimensions are subject to improvement without notice.

Air-cooled low temperature chiller technical parameters

Refrigerant: R404A Power supply: 460V-3N-60Hz

Model	Nominal cooling capacity		Compressor Input Power KW	Capacity control %	Refrigerant charge kg	Condenser	Evaporator				Axial Fan		Operating sound level dB(A)	Shipping weight kg	Operating weight kg
	kW	USRT					condenser Inlet outlet pipe diameter in	Chilled Water flow m3/h	Water Side Max. Pressure Mpa	Water pressure dropKPa	Air flow x 1000 m3/h	Power kW x number			
40STE-S140ADSL4	55.6	15.8	40.8	0%, 66%, 100%	30	Copper tube with corrugated aluminum fins	2-1/2"	10.1	1	28	40.2	2.0x2	68	1260	1370
40STE-S200ADSL4	78.4	22.3	56.9	0%, 50%, 75%, 100%	42		3"	14.3	1	55	57	1.2x4	68	1900	2080
40STE-S260ADSL4	104.8	29.8	75.1	0%, 50%, 75%, 100%	56		3"	19.1	1	64	80	2.0x4	72	2700	2920
40STE-S300ADSL4	124.0	35.3	87.7	0%, 50%, 75%, 100%	68		3"	22.6	1	66	80	2.0x4	72	2780	3020
40STE-S340ADSL4	145.6	41.4	101.7	0%, 50%, 75%, 100%	80		4"	26.5	1	42	85	1.2x6	72	3220	3380
40STE-S370ADSL4	156.8	44.6	110.4	0%, 50%, 75%, 100%	86		4"	28.5	1	54	121	2.0x6	72	3240	3620
40STE-S410ADSL4	170.4	48.5	119.6	0%, 50%, 75%, 100%	95		4"	31.0	1	44	121	2.0x6	72	3500	3880
40STE-S460ADDL4	195.2	55.5	138.4	0,25,37.5,50,62.5,75,87.5,100	115		4"	35.5	1	55	114	1.2x8	75	4780	4950
40STE-S520ADDL4	209.6	59.6	150.2		124		4"	38.1	1	65	161	2.0x8	75	4850	5130
40STE-S600ADDL4	248.0	70.5	175.4		135		4"	45.1	1	54	161	2.0x8	75	5360	5580
40STE-S680ADDL4	291.2	82.8	203.4		161		4"	53.0	1	65	170	1.6x12	75	5660	6100
40STE-S740ADDL4	313.6	89.2	220.8		175		4"	57.1	1	54	241	2.0x12	75	5720	6040

Note:

- Nominal cooling capacity benchmark: air dry / wet bulb temperature 35 °C / 24 °C, chilled water inlet and outlet water temperature -10 °C / -15 °C; fouling factor 0.018 m² · °C / kW;
- Chilled water temperature range: -15 °C ~ 5 °C
- Ambient temperature range: 5 °C ~ 43 °C
- Specifications and dimensions are subject to improvement without notice.

Air-cooled low temperature chiller dimension

PAC Low Temperature / Glycol Chiller

40STE series air-cooled low temperature chiller outline drawing

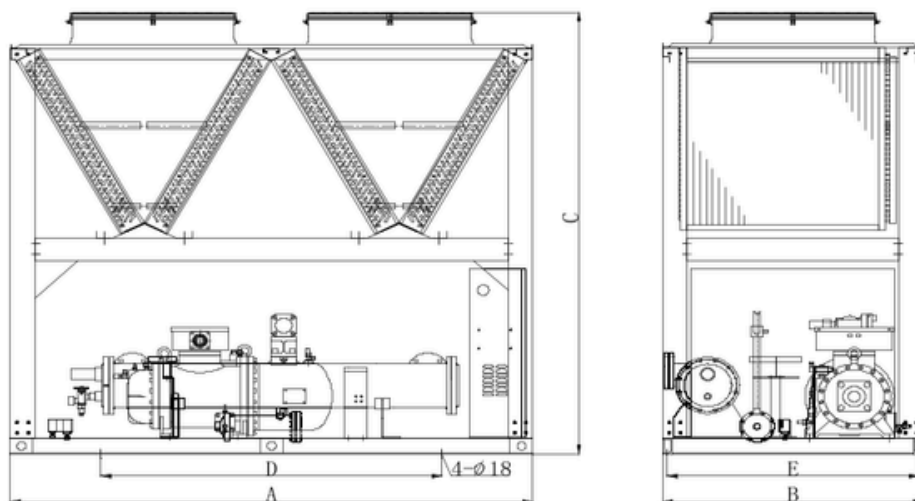

Model	A	B	C	D	E
40STE-(S)140ADS(L)(B)4	2250	1150	2300	1500	1100
40STE-(S)200ADS(L)(B)4	2250	2100	2300	1800	2050
40STE-(S)260ADS(L)(B)4	2250	2100	2300	1800	2050
40STE-(S)300ADS(L)(B)4	2480	2100	2400	1880	2050
40STE-(S)340ADS(L)(B)4	3400	2100	2400	1400	2050
40STE-(S)410ADS(L)(B)4	3400	2100	2400	1400	2050

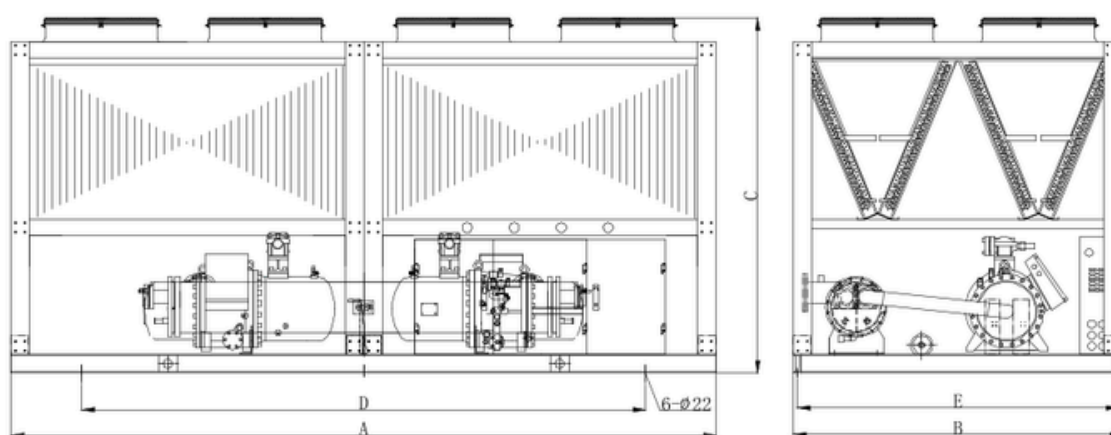

Model	A	B	C	D	E
40STE-(S)460ADD(L)(B)4	4500	2100	2400	1800	2050
40STE-(S)520ADD(L)(B)4	4500	2100	2400	1800	2050
40STE-(S)600ADD(L)(B)4	4960	2100	2400	1800	2050
40STE-(S)680ADD(L)(B)4	6800	2100	2400	3000	2050
40STE-(S)740ADD(L)(B)4	6800	2100	2400	3000	2050
40STE-(S)410ADS(L)(B)4	3400	2100	2400	1400	2050

Water-cooled low temperature chiller dimension / 50Hz

PAC Low Temperature / Glycol Chiller

Water-cooled low temperature chiller parameter (-5°C ~ 10°C)

Refrigerant: R22 Power supply: 380v-3N-50Hz

Model	Nominal cooling capacity		Compressor Input Power KW	Unit operating current A	Capacity control %	Refrigerant charge kg	Condenser				Evaporator				Operating sound level dB(A)	Shipping weight kg	Operating weight kg
	kW	USRT					Condenser Inlet outlet pipe diameter in	Chilled Water flowm ³ /h	Water Side Max. Pressure Mpa	Water pressure drop KPa	condenser Inlet outlet pipe diameter in	20% ethylene glycol solution flow	Water Side Max. Pressure Mpa	Water pressure drop KPa			
40STD-100WDSH4	72	21	22	38	0 66 100	18	2"	16	1	39	2"	13	1	24	73	980	1080
40STD-140WDSH4	100	29	29	51		25	2-1/2"	22	1	45	2-1/2"	18	1	31	74	1010	1120
40STD-180WDSH4	132	37	36	65		32	3"	29	1	43	3"	24	1	35	75	1200	1360
40STD-230WDSH4	176	50	48	85	0 50 75 100	42	3"	38	1	50	3"	32	1	39	75	1350	1530
40STD-260WDSH4	189	54	52	91		46	3"	42	1	50	3"	34	1	50	75	1540	1700
40STD-300WDSH4	223	63	59	103		55	3"	49	1	49	3"	41	1	49	75	1680	1850
40STD-340WDSH4	262	75	69	119		62	4"	57	1	47	4"	48	1	47	75	1800	1980
40STD-370WDSH4	283	80	75	128		68	4"	61	1	48	4"	51	1	73	75	1920	2080
40STD-410WDSH4	307	87	82	139		75	5"	67	1	48	4"	56	1	70	75	2030	2240
40STD-470WDSH4	373	106	98	167		90	5"	81	1	49	4"	68	1	47	75	2380	2660
40STD-550WDSH4	431	123	113	192		102	5"	94	1	48	5"	79	1	52	75	2520	2800
40STD-580WDSH4	467	133	121	205		110	5"	101	1	49	5"	85	1	69	75	2730	3020
40STD-620WDSH4	485	138	127	215		115	5"	105	1	55	5"	88	1	87	75	2820	3240
40STD-710WDSH4	565	161	145	244	0 25 33.5 50 62.5 75 87.5 100	134	5"	122	1	62	5"	103	1	44	75	2980	3400
40STD-790WDSH4	608	173	156	263		148	5"	131	1	64	5"	111	1	64	75	3220	3750
40STD-830WDSH4	662	188	170	286		158	5"	143	1	65	5"	120	1	76	75	3400	4000
40STD-930WDSH4	747	212	192	324		177	6"	161	1	67	6"	136	1	79	75	3680	4250
40STD-1090WDSH4	842	239	216	377		218	6"	182	1	70	8"	153	1	81	75	4150	4730
40STD-1280WDSH4	1079	307	268	459		256	8"	232	1	80	8"	196	1	84	75	4420	5020
40STD-1520WDSH4	1251	356	310	529		292	8"	268	1	84	8"	228	1	87	75	4780	5380
40STD-200WDDH4	144	41	44	76		36	3"	32	1	42	3"	26	1	34	75	1570	1990
40STD-460WDDH4	352	100	96	169		84	3"	77	1	45	4"	64	1	47	75	2510	3300
40STD-520WDDH4	379	108	104	182		92	4"	83	1	46	5"	69	1	59	75	2820	3700
40STD-680WDDH4	525	149	137	238	124	5"	114	1	47	5"	96	1	49	75	3250	4350	
40STD-1020WDDH4	780	222	201	345	188	4"*2	169	1	48	6"	142	1	52	75	4150	5370	
40STD-1100WDDH4	863	245	226	384	204	5"*2	187	1	49	6"	157	1	58	75	4390	5710	
40STD-1160WDDH4	934	266	242	410	220	5"*2	202	1	52	8"	170	1	57	75	4800	6390	
40STD-1240WDDH4	970	276	253	430	230	5"*2	210	1	55	8"	177	1	61	75	5340	6390	
40STD-1420WDDH4	1130	321	289	487	268	5"*2	244	1	62	8"	206	1	66	75	5850	6630	
40STD-1580WDDH4	1216	346	312	525	296	5"*2	263	1	64	8"	221	1	86	75	6310	6880	
40STD-1660WDDH4	1324	376	340	573	316	5"*2	286	1	70	8"	241	1	83	75	6540	7220	
40STD-1860WDDH4	1494	425	385	647	354	5"*2	323	1	77	8"	272	1	80	75	6790	7570	
40STD-2180WDDH4	1684	479	432	753	436	8"*2	364	1	80	10"	306	1	77	75	8200	9360	
40STD-2560WDDH4	2157	613	536	918	512	8"*2	463	1	83	10"	393	1	85	75	8900	10200	
40STD-3040WDDH4	2502	711	619	1058	584	8"*2	537	1	89	10"	455	1	92	75	9500	10800	
40STD-4560WDTH4	3753	1067	929	1587	876	8"*3	805	1	92	10"	683	1	97	75	12000	13300	

Note:

- Nominal cooling capacity reference: evaporator inlet and outlet water temperature 5 ° C / 0 ° C, condenser inlet and outlet water temperature 30 ° C / 35 ° C; fouling factor 0.018 m² • ° C / kW;
- Chilled water temperature range: -5 ° C ~ 10 ° C;
- Cooling water temperature range: 15 ° C ~ 40 ° C;
- Specifications and dimensions are subject to improvement without notice.

Water-cooled low temperature chiller parameters / 50Hz(continued)

PAC Low Temperature / Glycol Chiller

Water-cooled low temperature chiller parameter (-5°C ~ 10°C)

Refrigerant: R404A Power supply: 380v-3N-50Hz

Model	Nominal cooling capacity		Compressor Input Power kW	Unit operating current A	Capacity control %	Refrigerant charge kg	Condenser				Evaporator				Operating sound level dB(A)	Shipping weight kg	Operating weight kg
	kW	USRT					Condenser Inlet outlet pipe diameter in	Chilled Water flowm ³ /h	Water Side Max. Pressure Mpa	Water pressure drop KPa	condenser Inlet outlet pipe diameter in	20% ethylene glycol solution flow	Water Side Max. Pressure Mpa	Water pressure drop KPa			
40STD-S100WDSH4	73	21	26	45	0 66 100	18	2"	17	1	39	2"	13	1	24	73	980	1080
40STD-S140WDSH4	98	28	35	59		25	2-1/2"	23	1	45	2-1/2"	18	1	31	74	1010	1120
40STD-S180WDSH4	127	36	44	76		32	3"	29	1	43	3"	23	1	35	75	1200	1360
40STD-S230WDSH4	170	48	58	100	0 50 75 100	42	3"	39	1	50	3"	31	1	39	75	1350	1530
40STD-S260WDSH4	190	54	65	111		46	3"	44	1	50	3"	35	1	50	75	1540	1700
40STD-S300WDSH4	219	62	74	126		55	3"	50	1	49	3"	40	1	49	75	1680	1850
40STD-S340WDSH4	254	72	84	144		62	4"	58	1	47	4"	46	1	47	75	1800	1980
40STD-S370WDSH4	280	80	91	155		68	4"	64	1	48	4"	51	1	73	75	1920	2080
40STD-S410WDSH4	301	86	102	172		75	5"	69	1	48	4"	55	1	70	75	2030	2240
40STD-S470WDSH4	359	102	120	203		90	5"	82	1	49	4"	65	1	47	75	2380	2660
40STD-S550WDSH4	419	119	140	236		102	5"	96	1	48	5"	76	1	52	75	2520	2800
40STD-S580WDSH4	447	127	148	250		110	5"	102	1	49	5"	81	1	69	75	2730	3020
40STD-S620WDSH4	467	133	156	262		115	5"	107	1	55	5"	85	1	87	75	2820	3240
40STD-S710WDSH4	543	154	179	299	0 25 33.5 50 62.5 75 87.5 100	134	5"	124	1	62	5"	99	1	44	75	2980	3400
40STD-S790WDSH4	596	169	200	333		148	5"	137	1	64	5"	108	1	64	75	3220	3750
40STD-S830WDSH4	640	182	213	355		158	5"	147	1	65	5"	117	1	76	75	3400	4000
40STD-S930WDSH4	715	203	234	390		177	6"	163	1	67	6"	130	1	79	75	3680	4250
40STD-S1090WDSH4	814	232	268	460		218	6"	186	1	70	8"	148	1	81	75	4150	4730
40STD-S1280WDSH4	1054	300	352	559		256	8"	242	1	80	8"	192	1	84	75	4420	5020
40STD-S1520WDSH4	1195	340	397	664		292	8"	274	1	84	8"	217	1	87	75	4780	5380
40STD-S200WDDH4	148	42	53	90		36	3"	35	1	42	3"	27	1	34	75	1570	1990
40STD-S460WDDH4	339	97	116	200		84	3"	78	1	45	4"	62	1	47	75	2510	3300
40STD-S520WDDH4	380	108	130	222		92	4"	88	1	46	5"	69	1	59	75	2820	3700
40STD-S680WDDH4	507	144	168	287	124	5"	116	1	47	5"	92	1	49	75	3250	4350	
40STD-S1020WDDH4	757	215	254	429	188	4"*2	174	1	48	6"	138	1	52	75	4150	5370	
40STD-S1100WDDH4	838	238	280	472	204	5"*2	192	1	49	6"	152	1	58	75	4390	5710	
40STD-S1160WDDH4	893	254	297	500	220	5"*2	205	1	52	8"	163	1	57	75	4800	6390	
40STD-S1240WDDH4	934	266	311	524	230	5"*2	214	1	55	8"	170	1	61	75	5340	6390	
40STD-S1420WDDH4	1085	309	358	598	268	5"*2	248	1	62	8"	198	1	66	75	5850	6630	
40STD-S1580WDDH4	1192	339	399	667	296	5"*2	274	1	64	8"	217	1	86	75	6310	6880	
40STD-S1660WDDH4	1281	364	425	710	316	5"*2	293	1	70	8"	233	1	83	75	6540	7220	
40STD-S1860WDDH4	1429	406	468	781	354	5"*2	326	1	77	8"	260	1	80	75	6790	7570	
40STD-S2180WDDH4	1628	463	536	920	436	8"*2	372	1	80	10"	296	1	77	75	8200	9360	
40STD-S2560WDDH4	2109	600	704	1177	512	8"*2	484	1	83	10"	384	1	85	75	8900	10200	
40STD-S3040WDDH4	2389	679	794	1329	584	8"*2	547	1	89	10"	435	1	92	75	9500	10800	
40STD-S4560WDDH4	3584	1019	1191	1993	876	8"*3	821	1	92	10"	652	1	97	75	12000	13300	

Note:

- Nominal cooling capacity reference: evaporator inlet and outlet water temperature 5 °C / 0 °C, condenser inlet and outlet water temperature 30 °C / 35 °C; fouling factor 0.018 m² • °C / kW;
- Chilled water temperature range: -5 °C ~ 10 °C;
- Cooling water temperature range: 15 °C ~ 40 °C;
- Specifications and dimensions are subject to improvement without notice.

Water-cooled low temperature chiller parameters / 50Hz (continued)

PAC Low Temperature / Glycol Chiller

Water-cooled low temperature chiller parameter (-20°C ~ -5°C)

Refrigerant: R22

Power supply: 380v-3N-50Hz

Model	Nominal cooling capacity		Compressor Input Power kW	Unit operating current A	Capacity control %	Refrigerant charge kg	Condenser				Evaporator				Operating sound level dB(A)	Shipping weight kg	Operating weight kg	
	kW	USRT					Condenser Inlet outlet pipe diameter in	Chilled Water flowm ³ /h	Water Side Max. Pressure Mpa	Water pressure drop KPa	condenser Inlet outlet pipe diameter in	40% ethylene glycol solution flow	Water Side Max. Pressure Mpa	Water pressure drop KPa				
40STD-100WDSL4	45	13	20	36	0	18	2"	11	1	35	2"	9	1	26	73	1070	1170	
40STD-140WDSL4	62	18	27	48		66	25	2-1/2"	15	1	40	2-1/2"	12	1	34	74	1100	1210
40STD-180WDSL4	82	23	34	61		100	32	3"	20	1	39	3"	16	1	38	75	1290	1420
40STD-230WDSL4	109	31	44	77	0	42	3"	26	1	46	3"	22	1	43	75	1450	1630	
40STD-260WDSL4	117	33	48	84		66	46	3"	28	1	45	3"	23	1	55	75	1640	1800
40STD-300WDSL4	138	39	55	96		75	55	3"	33	1	44	3"	27	1	67	75	1780	1950
40STD-340WDSL4	162	46	64	111		84	62	4"	39	1	43	4"	32	1	74	75	2010	2190
40STD-370WDSL4	175	50	69	121		93	68	4"	42	1	43	4"	35	1	80	75	2130	2290
40STD-410WDSL4	190	54	76	137		102	75	4"	46	1	43	4"	38	1	77	75	2300	2510
40STD-470WDSL4	231	66	91	156		111	90	5"	55	1	44	4"	46	1	52	75	2650	2930
40STD-550WDSL4	267	76	105	182		120	102	5"	64	1	44	5"	53	1	57	75	2800	3080
40STD-580WDSL4	289	82	112	193		130	110	5"	69	1	44	5"	57	1	76	75	3010	3300
40STD-620WDSL4	300	85	118	203		140	115	5"	72	1	50	5"	59	1	96	75	3100	3530
40STD-710WDSL4	350	99	134	235		150	134	5"	83	1	56	5"	69	1	48	75	3300	3720
40STD-790WDSL4	376	107	145	244		160	148	5"	90	1	58	5"	74	1	70	75	3540	4070
40STD-830WDSL4	410	116	158	280		170	158	5"	98	1	59	5"	81	1	84	75	3820	4320
40STD-930WDSL4	462	131	178	313		180	177	6"	110	1	61	5"	91	1	87	75	4000	4570
40STD-1090WDSL4	595	169	223	389		190	218	6"	141	1	63	8"	118	1	90	75	4320	4580
40STD-1280WDSL4	667	190	249	430		200	256	8"	157	1	72	8"	132	1	92	75	4580	5180
40STD-1520WDSL4	774	220	287	499		210	292	8"	182	1	76	8"	153	1	95	75	4950	5550
40STD-200WDDL4	90	26	41	72	0	36	3"	22	1	38	3"	18	1	38	75	1740	2170	
40STD-460WDDL4	218	62	67	155		25	84	3"	49	1	41	5"	43	1	51	75	2680	3480
40STD-520WDDL4	234	67	97	167		33.5	92	5"	57	1	42	5"	46	1	46	75	3010	3920
40STD-680WDDL4	325	92	127	223		50	124	5"	78	1	42	5"	64	1	54	75	3660	4760
40STD-1020WDDL4	482	137	187	326		62.5	188	4"*2	115	1	43	6"	95	1	58	75	4560	5780
40STD-1100WDDL4	534	152	210	363		75	204	5"*2	128	1	44	6"	105	1	35	75	4940	6260
40STD-1160WDDL4	578	164	225	386		87.5	220	5"*2	138	1	47	8"	114	1	38	75	5350	6700
40STD-1240WDDL4	600	171	235	405		100	230	5"*2	144	1	50	8"	119	1	68	75	5890	6940
40STD-1420WDDL4	699	199	268	470		25	268	5"*2	166	1	56	8"	138	1	73	75	6390	7170
40STD-1580WDDL4	752	214	289	488		33.5	296	5"*2	179	1	58	8"	149	1	98	75	6850	7430
40STD-1660WDDL4	819	233	316	560		50	316	5"*2	195	1	63	8"	162	1	63	75	7080	7760
40STD-1860WDDL4	924	263	356	625		62.5	354	6"*2	220	1	69	8"	183	1	69	75	7330	8110
40STD-2180WDDL4	1189	338	445	778		75	436	6"*2	281	1	72	8"	235	1	72	75	9000	10160
40STD-2560WDDL4	1334	379	497	860		87.5	512	8"*2	315	1	75	10"	264	1	75	75	9700	11000
40STD-3040WDDL4	1548	440	574	997		100	584	8"*2	365	1	80	10"	306	1	80	75	10300	11600
40STD-4560WDTL4	2322	650	861	1496		25	876	8"*3	547	1	92	10"	459	1	97	75	14000	15200

Note:

- Nominal cooling capacity reference: evaporator inlet and outlet water temperature -10° C / -15° C, condenser inlet and outlet water temperature 30 ° C / 35 ° C; fouling factor 0.018 m² • ° C / kW;
- Chilled water temperature range: -20° C ~ -5° C ;
- Cooling water temperature range: 15 ° C ~ 40 ° C ;
- Specifications and dimensions are subject to improvement without notice.

Water-cooled low temperature chiller parameters / 50Hz (continued)

PAC Low Temperature / Glycol Chiller

Water-cooled low temperature chiller parameter (-20°C ~ -5°C)

Refrigerant: R404A Power supply: 380v-3N-50Hz

Model	Nominal cooling capacity		Compressor Input Power kW	Unit operating current A	Capacity control %	Refrigerant charge kg	Condenser				Evaporator				Operating sound level dB(A)	Shipping weight kg	Operating weight kg		
	kW	USRT					Condenser Inlet outlet pipe diameter in	Chilled Water flow m ³ /h	Water Side Max. Pressure Mpa	Water pressure drop KPa	condenser Inlet outlet pipe diameter in	20% ethylene glycol solution flow	Water Side Max. Pressure Mpa	Water pressure drop KPa					
40STD-S100WDSL4	47	13	26	44	0	18	2"	12	1	35	2"	9	1	26	73	1070	1170		
40STD-S140WDSL4	65	18	34	58		66	25	2-1/2"	17	1	40	2-1/2"	13	1	34	74	1100	1210	
40STD-S180WDSL4	85	24	43	74		100	32	3"	22	1	39	3"	17	1	38	75	1290	1420	
40STD-S230WDSL4	114	32	56	95	0	42	3"	29	1	46	3"	23	1	43	75	1450	1630		
40STD-S260WDSL4	122	35	61	104		66	46	3"	32	1	45	3"	24	1	55	75	1640	1800	
40STD-S300WDSL4	145	41	69	120		100	55	3"	37	1	44	3"	29	1	67	75	1780	1950	
40STD-S340WDSL4	170	48	80	140		66	62	4"	43	1	43	4"	34	1	74	75	2010	2190	
40STD-S370WDSL4	183	52	87	151		100	68	4"	46	1	43	4"	36	1	80	75	2130	2290	
40STD-S410WDSL4	199	57	96	168		66	75	4"	51	1	43	4"	39	1	77	75	2300	2510	
40STD-S470WDSL4	242	69	115	196		100	90	5"	61	1	44	4"	48	1	52	75	2650	2930	
40STD-S550WDSL4	280	80	133	225		0	102	5"	71	1	44	5"	55	1	57	75	2800	3080	
40STD-S580WDSL4	303	86	142	239		75	110	5"	76	1	44	5"	60	1	76	75	3010	3300	
40STD-S620WDSL4	315	89	148	255		100	115	5"	80	1	50	5"	62	1	96	75	3100	3530	
40STD-S710WDSL4	367	104	169	291	0	134	5"	92	1	56	5"	72	1	48	75	3300	3720		
40STD-S790WDSL4	395	112	182	306		75	148	5"	99	1	58	5"	78	1	70	75	3540	4070	
40STD-S830WDSL4	429	122	199	345		100	158	5"	108	1	59	5"	85	1	84	75	3820	4320	
40STD-S930WDSL4	484	138	225	392		66	177	6"	122	1	61	5"	96	1	87	75	4000	4570	
40STD-S1090WDSL4	624	178	281	485		100	218	6"	156	1	63	8"	123	1	90	75	4320	4580	
40STD-S1280WDSL4	700	199	314	532		75	256	8"	174	1	72	8"	138	1	92	75	4580	5180	
40STD-S1520WDSL4	813	231	362	621		100	292	8"	202	1	76	8"	161	1	95	75	4950	5550	
40STD-S200WDDL4	93	27	51	87		0	36	3"	25	1	38	3"	18	1	38	75	1740	2170	
40STD-S460WDDL4	228	65	112	191			25	84	3"	58	1	41	5"	45	1	51	75	2680	3480
40STD-S520WDDL4	245	70	122	207			33.5	92	5"	63	1	42	5"	48	1	46	75	3010	3920
40STD-S680WDDL4	340	97	161	280	50		124	5"	86	1	42	5"	67	1	54	75	3660	4760	
40STD-S1020WDDL4	506	144	235	403	62.5		188	4"*2	127	1	43	6"	100	1	58	75	4560	5780	
40STD-S1100WDDL4	559	159	265	449	75		204	5"*2	142	1	44	6"	111	1	35	75	4940	6260	
40STD-S1160WDDL4	606	172	283	479	87.5		220	5"*2	153	1	47	8"	120	1	38	75	5350	6700	
40STD-S1240WDDL4	629	179	297	510	100		230	5"*2	159	1	50	8"	124	1	68	75	5890	6940	
40STD-S1420WDDL4	733	208	338	581	62.5		268	5"*2	184	1	56	8"	145	1	73	75	6390	7170	
40STD-S1580WDDL4	789	224	365	611	75		296	5"*2	198	1	58	8"	156	1	98	75	6850	7430	
40STD-S1660WDDL4	858	244	392	691	87.5	316	5"*2	215	1	63	8"	170	1	63	75	7080	7760		
40STD-S1860WDDL4	968	275	450	784	100	354	6"*2	244	1	69	8"	191	1	69	75	7330	8110		
40STD-S2180WDDL4	1249	355	562	970	0	436	6"*2	311	1	72	8"	247	1	72	75	9000	10160		
40STD-S2560WDDL4	1401	398	627	1064		62.5	512	8"*2	349	1	75	10"	277	1	75	75	9700	11000	
40STD-S3040WDDL4	1626	462	724	1242		75	584	8"*2	404	1	80	10"	321	1	80	75	10300	11600	
40STD-S4560WDTL4	2439	693	1086	1863		100	876	8"*3	606	1	92	10"	482	1	97	75	14000	15200	

Note:

- Nominal cooling capacity reference: evaporator inlet and outlet water temperature -10° C / -15 ° C, condenser inlet and outlet water temperature 30 ° C / 35 ° C; fouling factor 0.018 m² • ° C / kW;
- Chilled water temperature range: -20° C ~ -5° C;
- Cooling water temperature range: 15 ° C ~ 40 ° C;
- Specifications and dimensions are subject to improvement without notice.

Water-cooled low temperature chiller parameters / 50Hz (continued)

PAC Low Temperature / Glycol Chiller

Water-cooled low temperature chiller parameter (-35°C ~ -20°C)

Refrigerant: R22 Power supply: 380v-3N-50Hz

Model	Nominal cooling capacity		Compressor Input Power kW	Unit operating current A	Capacity control %	Refrigerant charge kg	Condenser				Evaporator			Operating sound level dB(A)	Shipping weight kg	Operating weight kg	
	kW	USRT					Condenser Inlet outlet pipe diameter in	Chilled Water flow m ³ /h	Water Side Max. Pressure Mpa	Water pressure drop KPa	condenser Inlet outlet pipe diameter in	55% ethylene glycol solution flow	Water Side Max. Pressure Mpa				Water pressure drop KPa
40STD-100WDSC4	18	5	17	32	0 66 100	18	2"	6	1	35	2"	4	1	27	75	1100	1200
40STD-140WDSC4	26	7	23	42		25	2-1/2"	8	1	40	2-1/2"	6	1	34	75	1160	1270
40STD-180WDSC4	34	10	29	55		32	3"	11	1	39	3"	7	1	39	75	1340	1510
40STD-230WDSC4	45	13	39	69		42	3"	14	1	46	3"	10	1	43	75	1500	1680
40STD-260WDSC4	48	14	42	74		46	3"	16	1	45	3"	11	1	56	75	1670	1830
40STD-300WDSC4	57	16	48	85		55	3"	18	1	44	3"	13	1	27	75	1820	1990
40STD-340WDSC4	67	19	56	98		62	4"	21	1	43	4"	15	1	26	75	2070	2260
40STD-370WDSC4	72	21	67	106		68	4"	24	1	43	4"	16	1	82	75	2190	2350
40STD-410WDSC4	78	22	68	122		75	4"	25	1	44	4"	17	1	53	75	2380	2590
40STD-470WDSC4	95	27	80	140		90	5"	30	1	90	4"	21	1	44	75	2720	3000
40STD-550WDSC4	110	31	92	161	0 50 75 100	102	5"	35	1	44	5"	24	1	58	75	2830	3120
40STD-580WDSC4	119	34	99	172		110	5"	38	1	44	5"	26	1	78	75	3060	3350
40STD-620WDSC4	124	35	103	178		115	5"	39	1	50	5"	27	1	98	75	3160	3580
40STD-710WDSC4	144	41	119	209		134	5"	45	1	56	5"	32	1	49	75	3350	3770
40STD-790WDSC4	155	44	128	218		148	5"	49	1	58	5"	34	1	71	75	3590	4120
40STD-830WDSC4	169	48	140	250		158	5"	53	1	59	5"	37	1	85	75	3870	4370
40STD-930WDSC4	191	54	158	279		177	6"	60	1	61	5"	42	1	88	75	4050	4620
40STD-1090WDSC4	246	70	200	353		218	6"	77	1	63	8"	54	1	91	75	4380	4960
40STD-1280WDSC4	276	78	223	391		256	8"	86	1	72	8"	61	1	94	75	4640	5240
40STD-1520WDSC4	320	91	257	453		292	8"	99	1	76	8"	71	1	97	75	5020	5610
40STD-200WDDC4	37	10	34	63	0 25 33.5 50 62.5 75 87.5 100	36	3"	12	1	36	3"	8	1	38	75	1820	2250
40STD-460WDDC4	90	25	77	137		84	4"	29	1	84	5"	20	1	52	75	2760	3560
40STD-520WDDC4	96	27	84	147		92	5"	31	1	92	5"	21	1	42	75	3100	4010
40STD-680WDDC4	134	38	112	196		124	5"	42	1	42	5"	30	1	55	75	3760	4860
40STD-1020WDDC4	199	57	173	291		188	4"*2	60	1	43	6"	44	1	59	75	4650	5870
40STD-1100WDDC4	220	63	185	323		204	5"*2	70	1	44	6"	49	1	65	75	5030	6350
40STD-1160WDDC4	239	68	198	344		220	5"*2	75	1	47	8"	53	1	64	75	5440	6790
40STD-1240WDDC4	248	70	207	357		230	5"*2	78	1	50	8"	55	1	69	75	6020	7060
40STD-1420WDDC4	289	82	237	419		268	5"*2	90	1	56	8"	64	1	75	75	6510	7290
40STD-1580WDDC4	311	88	256	436		296	5"*2	97	1	58	8"	69	1	97	75	6970	7550
40STD-1660WDDC4	338	96	279	500	316	5"*2	106	1	63	8"	75	1	93	75	7200	7880	
40STD-1860WDDC4	381	108	315	557	354	6"*2	120	1	69	8"	84	1	90	75	7450	8230	
40STD-2180WDDC4	491	140	400	706	436	6"*2	153	1	72	8"	108	1	87	75	9120	10280	
40STD-2560WDDC4	551	157	446	783	512	8"*2	172	1	75	10"	122	1	96	75	9820	11150	
40STD-3040WDDC4	640	182	515	905	584	8"*2	199	1	80	10"	141	1	104	75	10450	11720	
40STD-4560WDTC4	960	273	772	1358	876	8"*3	298	1	92	10"	212	1	105	75	14000	15200	

Note:

- Nominal cooling capacity reference: evaporator inlet and outlet water temperature -30° C / -35° C, condenser inlet and outlet water temperature 30° C / 35° C; fouling factor 0.018 m² • ° C /kW;
- Chilled water temperature range: -35° C ~ -20° C;
- Cooling water temperature range: 15° C ~ 40° C
- Specifications and dimensions are subject to improvement without notice.

Water-cooled low temperature chiller parameters / 50Hz (continued)

PAC Low Temperature / Glycol Chiller

Water-cooled low temperature chiller parameter(-35°C ~ -20°C)

Refrigerant: R404A Power supply: 380v-3N-50Hz

Model	Nominal cooling capacity		Compressor Input Power kW	Unit operating current A	Capacity control %	Refrigerant charge kg	Condenser				Evaporator				Operating sound level dB(A)	Shipping weight kg	Operating weight kg
	kW	USRT					Condenser Inlet outlet pipe diameter in	Chilled Water flowm ³ /h	Water Side Max. Pressure Mpa	Water pressure drop KPa	condenser Inlet outlet pipe diameter in	55% ethylene glycol solution flow	Water Side Max. Pressure Mpa	Water pressure drop KPa			
40STD-S100WDSC4	18	5	19	34	0 66 100	18	2"	6	1	35	2"	4	1	27	75	1100	1200
40STD-S140WDSC4	25	7	26	46		25	2-1/2"	9	1	40	2-1/2"	5	1	34	75	1160	1270
40STD-S180WDSC4	32	9	33	60		32	3"	11	1	39	3"	7	1	39	75	1340	1510
40STD-S230WDSC4	43	12	43	75		42	3"	15	1	46	3"	10	1	43	75	1500	1680
40STD-S260WDSC4	46	13	47	81		46	3"	16	1	45	3"	10	1	56	75	1670	1830
40STD-S300WDSC4	55	16	54	95		55	3"	19	1	44	3"	12	1	27	75	1820	1990
40STD-S340WDSC4	64	18	63	110		62	4"	22	1	43	4"	14	1	26	75	2070	2260
40STD-S370WDSC4	69	20	68	119		68	4"	24	1	43	4"	15	1	82	75	2190	2350
40STD-S410WDSC4	75	21	75	134		75	4"	25	1	44	4"	17	1	53	75	2380	2590
40STD-S470WDSC4	92	26	90	156		90	5"	31	1	90	4"	20	1	44	75	2720	3000
40STD-S550WDSC4	106	30	104	179	0 50 75 100	102	5"	36	1	44	5"	23	1	58	75	2830	3120
40STD-S580WDSC4	115	33	111	191		110	5"	39	1	44	5"	25	1	78	75	3060	3350
40STD-S620WDSC4	119	34	116	200		115	5"	41	1	50	5"	26	1	98	75	3160	3580
40STD-S710WDSC4	139	40	133	234		134	5"	47	1	56	5"	31	1	49	75	3350	3770
40STD-S790WDSC4	150	43	144	243		148	5"	50	1	58	5"	33	1	71	75	3590	4120
40STD-S830WDSC4	163	46	157	278		158	5"	55	1	59	5"	36	1	85	75	3870	4370
40STD-S930WDSC4	184	52	177	310		177	6"	62	1	61	5"	41	1	88	75	4050	4620
40STD-S1090WDSC4	237	67	224	391		218	6"	79	1	63	8"	52	1	91	75	4380	4960
40STD-S1280WDSC4	266	76	250	433		256	8"	89	1	72	8"	59	1	94	75	4640	5240
40STD-S1520WDSC4	311	88	310	535		292	8"	107	1	76	8"	69	1	97	75	5020	5610
40STD-S200WDDC4	35	10	38	69	0 25 33.5 50 62.5 75 87.5 100	36	3"	13	1	36	3"	8	1	38	75	1820	2250
40STD-S460WDDC4	86	25	86	151		84	4"	30	1	84	5"	19	1	52	75	2760	3560
40STD-S520WDDC4	93	26	94	162		92	5"	32	1	92	5"	20	1	42	75	3100	4010
40STD-S680WDDC4	129	37	126	220		124	5"	44	1	42	5"	28	1	55	75	3760	4860
40STD-S1020WDDC4	192	55	185	323		188	4**2	60	1	43	6"	42	1	59	75	4650	5870
40STD-S1100WDDC4	212	60	207	358		204	5**2	72	1	44	6"	47	1	65	75	5030	6350
40STD-S1160WDDC4	230	65	222	383		220	5**2	78	1	47	8"	51	1	64	75	5440	6790
40STD-S1240WDDC4	239	68	232	400		230	5**2	81	1	50	8"	53	1	69	75	6020	7060
40STD-S1420WDDC4	278	79	267	468		268	5**2	94	1	56	8"	61	1	75	75	6510	7290
40STD-S1580WDDC4	299	85	288	486		296	5**2	101	1	58	8"	66	1	97	75	6970	7550
40STD-S1660WDDC4	325	93	313	556	316	5**2	110	1	63	8"	72	1	93	75	7200	7880	
40STD-S1860WDDC4	367	104	354	621	354	6**2	124	1	69	8"	82	1	90	75	7450	8230	
40STD-S2180WDDC4	473	135	447	781	436	6**2	158	1	72	8"	105	1	87	75	9120	10280	
40STD-S2560WDDC4	531	151	501	866	512	8**2	177	1	75	10"	117	1	96	75	9820	11150	
40STD-S3040WDDC4	621	177	619	1070	584	8**2	213	1	80	10"	137	1	104	75	10450	11720	
40STD-S4560WDTC4	932	265	929	1605	876	8**3	320	1	92	10"	206	1	105	75	14000	15200	

Note:

- Nominal cooling capacity reference: evaporator inlet and outlet water temperature -30° C / -35° C, condenser inlet and outlet water temperature 30° C / 35° C; fouling factor 0.018 m² • ° C / kW;
- Chilled water temperature range: -35° C ~ -20° C
- Cooling water temperature range: 15° C ~ 40° C
- Specifications and dimensions are subject to improvement without notice.

Water-cooled low temperature chiller dimension / 60Hz

PAC Low Temperature / Glycol Chiller

Water-cooled low temperature chiller parameter (-5°C ~ 10°C)

Refrigerant: R22

Power supply: 460V-3N-60Hz

Model	Nominal cooling capacity		Compressor Input Power KW	Unit operating current A	Capacity control %	Refrigerant charge kg	Condenser				Evaporator				Operating sound level dB(A)	Shipping weight kg	Operating weight kg
	kW	USRT					Condenser Inlet outlet pipe diameter in	Chilled Water flowm3/h	Water Side Max. Pressure Mpa	Water pressure drop KPa	condenser Inlet outlet pipe diameter in	20% ethylene glycol solution flow	Water Side Max. Pressure Mpa	Water pressure drop KPa			
40STD-100WDSH4	87	25	26	37	0 66 100	18	2"	19	1	39	2"	16	1	24	73	1078	1188
40STD-140WDSH4	120	34	35	49		25	2-1/2"	27	1	45	2-1/2"	22	1	31	74	1111	1232
40STD-180WDSH4	158	45	44	62		32	3"	35	1	43	3"	29	1	35	75	1320	1496
40STD-230WDSH4	211	60	57	81	0 50 75 100	42	3"	46	1	50	3"	38	1	39	75	1485	1683
40STD-260WDSH4	227	65	63	88		46	3"	50	1	50	3"	41	1	50	75	1694	1870
40STD-300WDSH4	268	76	71	101		55	3"	58	1	49	3"	49	1	49	75	1848	2035
40STD-340WDSH4	315	90	82	119		62	4"	68	1	47	4"	57	1	47	75	1980	2178
40STD-370WDSH4	339	96	89	128		68	4"	74	1	48	4"	62	1	73	75	2112	2288
40STD-410WDSH4	369	105	99	142		75	5"	80	1	48	4"	67	1	70	75	2233	2464
40STD-470WDSH4	448	127	118	166		90	5"	97	1	49	4"	81	1	47	75	2618	2926
40STD-550WDSH4	518	147	136	191		102	5"	112	1	48	5"	94	1	52	75	2772	3080
40STD-580WDSH4	561	159	145	203		110	5"	121	1	49	5"	102	1	69	75	3003	3322
40STD-620WDSH4	582	166	152	216		115	5"	126	1	55	5"	106	1	87	75	3102	3564
40STD-710WDSH4	678	193	173	246	0 25 33.5 50 62.5 75 87.5 100	134	5"	146	1	62	5"	123	1	44	75	3278	3740
40STD-790WDSH4	730	207	187	259		148	5"	158	1	64	5"	133	1	64	75	3542	4125
40STD-830WDSH4	794	226	204	293		158	5"	172	1	65	5"	145	1	76	75	3740	4400
40STD-930WDSH4	896	255	231	333		177	6"	194	1	67	6"	163	1	79	75	4048	4675
40STD-1090WDSH4	1011	287	259	371		218	6"	218	1	70	8"	184	1	81	75	4565	5203
40STD-1280WDSH4	1294	368	322	451		256	8"	278	1	80	8"	236	1	84	75	4862	5522
40STD-1520WDSH4	1501	427	372	527		292	8"	322	1	84	8"	273	1	87	75	5258	5918
40STD-200WDDH4	173	49	53	74		36	3"	39	1	42	3"	31	1	34	75	1727	2189
40STD-460WDDH4	422	120	115	162		84	3"	92	1	45	4"	77	1	47	75	2761	3630
40STD-520WDDH4	454	129	125	176		92	4"	100	1	46	5"	83	1	59	75	3102	4070
40STD-680WDDH4	630	179	165	238	124	5"	137	1	47	5"	115	1	49	75	3575	4785	
40STD-1020WDDH4	936	266	241	342	188	4*2	203	1	48	6"	170	1	52	75	4565	5907	
40STD-1100WDDH4	1035	294	272	381	204	5*2	225	1	49	6"	188	1	58	75	4829	6281	
40STD-1160WDDH4	1121	319	291	406	220	5*2	243	1	52	8"	204	1	57	75	5280	7029	
40STD-1240WDDH4	1164	331	304	433	230	5*2	253	1	55	8"	212	1	61	75	5874	7029	
40STD-1420WDDH4	1356	386	347	493	268	5*2	293	1	62	8"	247	1	66	75	6435	7293	
40STD-1580WDDH4	1459	415	374	519	296	5*2	315	1	64	8"	266	1	86	75	6941	7568	
40STD-1660WDDH4	1589	452	408	586	316	5*2	343	1	70	8"	289	1	83	75	7194	7942	
40STD-1860WDDH4	1792	510	462	666	354	5*2	388	1	77	8"	326	1	80	75	7469	8327	
40STD-2180WDDH4	2021	575	518	743	436	8*2	437	1	80	10"	368	1	77	75	9020	10296	
40STD-2560WDDH4	2588	736	644	903	512	8*2	556	1	83	10"	471	1	85	75	9790	11220	
40STD-3040WDDH4	3002	854	743	1055	584	8*2	644	1	89	10"	546	1	92	75	10450	11880	
40STD-4560WDDH4	4503	1280	1115	1582	876	8*3	966	1	92	10"	819	1	97	75	13200	14630	

Note:

- Nominal cooling capacity reference: evaporator inlet and outlet water temperature 5 ° C / 0 ° C, condenser inlet and outlet water temperature 30 ° C / 35 ° C; fouling factor 0.018 m² • ° C / kW;
- Chilled water temperature range: -5 ° C ~ 10 ° C;
- Cooling water temperature range: 15 ° C ~ 40 ° C;
- Specifications and dimensions are subject to improvement without notice.

Water-cooled low temperature chiller parameters / 60Hz(continued)

PAC Low Temperature / Glycol Chiller

Water-cooled low temperature chiller parameter (-5°C ~ 10°C)

Refrigerant: R404A Power supply: 460V-3N-60Hz

Model	Nominal cooling capacity		Compressor Input Power kW	Unit operating current A	Capacity control %	Refrigerant charge kg	Condenser				Evaporator				Operating sound level dB(A)	Shipping weight kg	Operating weight kg	
	kW	USRT					Condenser Inlet outlet pipe diameter in	Chilled Water flowm ³ /h	Water Side Max. Pressure Mpa	Water pressure drop KPa	condenser Inlet outlet pipe diameter in	20% ethylene glycol solution flow	Water Side Max. Pressure Mpa	Water pressure drop KPa				
40STD-S100WDSH4	88	25	32	44	0 66 100	18	2"	21	1	39	2"	16	1	24	73	1078	1188	
40STD-S140WDSH4	122	35	42	58		25	2-1/2"	28	1	45	2-1/2"	22	1	31	74	1111	1232	
40STD-S180WDSH4	159	45	53	74		32	3"	37	1	43	3"	29	1	35	75	1320	1496	
40STD-S230WDSH4	214	61	69	97	0 50 75 100	42	3"	49	1	50	3"	39	1	39	75	1485	1683	
40STD-S260WDSH4	229	65	76	105		46	3"	52	1	50	3"	42	1	50	75	1694	1870	
40STD-S300WDSH4	271	77	85	120		55	3"	61	1	49	3"	49	1	49	75	1848	2035	
40STD-S340WDSH4	319	91	101	141		62	4"	72	1	47	4"	58	1	47	75	1980	2178	
40STD-S370WDSH4	343	98	108	153		68	4"	78	1	48	4"	62	1	73	75	2112	2288	
40STD-S410WDSH4	373	106	119	170		75	5"	85	1	48	4"	68	1	70	75	2233	2464	
40STD-S470WDSH4	453	129	142	202		90	5"	102	1	49	4"	83	1	47	75	2618	2926	
40STD-S550WDSH4	524	149	164	229		102	5"	118	1	48	5"	95	1	52	75	2772	3080	
40STD-S580WDSH4	568	162	178	246		110	5"	128	1	49	5"	103	1	69	75	3003	3322	
40STD-S620WDSH4	590	168	183	259		115	5"	133	1	55	5"	107	1	87	75	3102	3564	
40STD-S710WDSH4	651	185	215	294	0 25 33.5 50 62.5 75 87.5 100	134	5"	149	1	62	5"	119	1	44	75	3278	3740	
40STD-S790WDSH4	715	203	240	313		148	5"	164	1	64	5"	130	1	64	75	3542	4125	
40STD-S830WDSH4	768	219	255	351		158	5"	176	1	65	5"	140	1	76	75	3740	4400	
40STD-S930WDSH4	858	244	281	403		177	6"	196	1	67	6"	156	1	79	75	4048	4675	
40STD-S1090WDSH4	977	278	321	446		218	6"	223	1	70	8"	178	1	81	75	4565	5203	
40STD-S1280WDSH4	1265	360	422	541		256	8"	290	1	80	8"	230	1	84	75	4862	5522	
40STD-S1520WDSH4	1434	408	477	640		292	8"	328	1	84	8"	261	1	87	75	5258	5918	
40STD-S200WDDH4	178	50	64	88		0 25 33.5 50 62.5 75 87.5 100	36	3"	41	1	42	3"	32	1	34	75	1727	2189
40STD-S460WDDH4	407	116	139	194			84	3"	94	1	45	4"	74	1	47	75	2761	3630
40STD-S520WDDH4	456	130	156	211			92	4"	105	1	46	5"	83	1	59	75	3102	4070
40STD-S680WDDH4	609	173	202	283	124		5"	139	1	47	5"	111	1	49	75	3575	4785	
40STD-S1020WDDH4	909	258	305	407	188		4"*2	209	1	48	6"	165	1	52	75	4565	5907	
40STD-S1100WDDH4	1005	286	336	459	204		5"*2	231	1	49	6"	183	1	58	75	4829	6281	
40STD-S1160WDDH4	1072	305	356	493	220		5"*2	246	1	52	8"	195	1	57	75	5280	7029	
40STD-S1240WDDH4	1121	319	373	517	230		5"*2	257	1	55	8"	204	1	61	75	5874	7029	
40STD-S1420WDDH4	1302	370	430	588	268		5"*2	298	1	62	8"	237	1	66	75	6435	7293	
40STD-S1580WDDH4	1430	407	479	625	296		5"*2	328	1	64	8"	260	1	86	75	6941	7568	
40STD-S1660WDDH4	1537	437	510	702	0 25 33.5 50 62.5 75 87.5 100	316	5"*2	352	1	70	8"	280	1	83	75	7194	7942	
40STD-S1860WDDH4	1715	488	562	805		354	5"*2	392	1	77	8"	312	1	80	75	7469	8327	
40STD-S2180WDDH4	1954	556	643	893		436	8"*2	447	1	80	10"	356	1	77	75	9020	10296	
40STD-S2560WDDH4	2531	720	845	1081		512	8"*2	580	1	83	10"	461	1	85	75	9790	11220	
40STD-S3040WDDH4	2867	815	953	1278		584	8"*2	657	1	89	10"	522	1	92	75	10450	11880	
40STD-S4560WDDH4	4301	1223	1430	1918		876	8"*3	985	1	92	10"	783	1	97	75	13200	14630	

Note:

- Nominal cooling capacity reference: evaporator inlet and outlet water temperature 5 °C / 0 °C, condenser inlet and outlet water temperature 30 °C / 35 °C; fouling factor 0.018 m² • °C / kW;
- Chilled water temperature range: -5 °C ~ 10 °C;
- Cooling water temperature range: 15 °C ~ 40 °C;
- Specifications and dimensions are subject to improvement without notice.

Water-cooled low temperature chiller parameters / 60Hz (continued)

PAC Low Temperature / Glycol Chiller

Water-cooled low temperature chiller parameter (-20°C ~ -5°C)

Refrigerant: R22

Power supply: 460V-3N-60Hz

Model	Nominal cooling capacity		Compressor Input Power kW	Unit operating current A	Capacity control %	Refrigerant charge kg	Condenser				Evaporator				Operating sound level dB(A)	Shipping weight kg	Operating weight kg	
	kW	USRT					Condenser Inlet outlet pipe diameter in	Chilled Water flowm ³ /h	Water Side Max. Pressure Mpa	Water pressure drop KPa	condenser Inlet outlet pipe diameter in	40% ethylene glycol solution flow	Water Side Max. Pressure Mpa	Water pressure drop KPa				
40STD-100WDSL4	54	15	24	35	0	18	2"	13	1	35	2"	11	1	26	73	1177	1287	
40STD-140WDSL4	75	21	32	46		66	25	2-1/2"	18	1	40	2-1/2"	15	1	34	74	1210	1331
40STD-180WDSL4	98	28	40	58		100	32	3"	24	1	39	3"	19	1	38	75	1419	1562
40STD-230WDSL4	131	37	53	75	0	42	3"	32	1	46	3"	26	1	43	75	1595	1793	
40STD-260WDSL4	141	40	58	82		66	46	3"	34	1	45	3"	28	1	55	75	1804	1980
40STD-300WDSL4	166	47	66	95		100	55	3"	40	1	44	3"	33	1	67	75	1958	2145
40STD-340WDSL4	195	55	76	110		66	62	4"	47	1	43	4"	39	1	74	75	2211	2409
40STD-370WDSL4	210	60	83	120		75	68	4"	50	1	43	4"	41	1	80	75	2343	2519
40STD-410WDSL4	228	65	91	133		84	75	4"	55	1	43	4"	45	1	77	75	2530	2761
40STD-470WDSL4	277	79	109	155		93	90	5"	66	1	44	4"	55	1	52	75	2915	3223
40STD-550WDSL4	320	91	126	178		102	102	5"	77	1	44	5"	63	1	57	75	3080	3388
40STD-580WDSL4	347	99	135	189		110	110	5"	83	1	44	5"	69	1	76	75	3311	3630
40STD-620WDSL4	360	102	141	201		115	115	5"	86	1	50	5"	71	1	96	75	3410	3883
40STD-710WDSL4	420	119	161	230		134	134	5"	100	1	56	5"	83	1	48	75	3630	4092
40STD-790WDSL4	451	128	173	241		148	148	5"	107	1	58	5"	89	1	70	75	3894	4477
40STD-830WDSL4	491	140	189	273		158	158	5"	117	1	59	5"	97	1	84	75	4202	4752
40STD-930WDSL4	554	158	214	309		177	177	6"	132	1	61	5"	110	1	87	75	4400	5027
40STD-1090WDSL4	714	203	267	346		218	218	6"	169	1	63	8"	141	1	90	75	4752	5038
40STD-1280WDSL4	801	228	298	421		256	256	8"	189	1	72	8"	158	1	92	75	5038	5698
40STD-1520WDSL4	929	264	344	490		292	292	8"	219	1	76	8"	184	1	95	75	5445	6105
40STD-200WDDL4	108	31	49	69	0	36	3"	27	1	38	3"	21	1	38	75	1914	2387	
40STD-460WDDL4	261	74	80	151		84	84	3"	59	1	41	5"	52	1	51	75	2948	3828
40STD-520WDDL4	281	80	116	163		92	92	5"	68	1	42	5"	56	1	46	75	3311	4312
40STD-680WDDL4	390	111	153	221		124	124	5"	93	1	42	5"	77	1	54	75	4026	5236
40STD-1020WDDL4	578	164	224	319		188	188	4"*2	138	1	43	6"	114	1	58	75	5016	6358
40STD-1100WDDL4	641	182	252	355		204	204	5"*2	153	1	44	6"	127	1	35	75	5434	6886
40STD-1160WDDL4	694	197	270	378		220	220	5"*2	166	1	47	8"	137	1	38	75	5885	7370
40STD-1240WDDL4	720	205	282	402		230	230	5"*2	172	1	50	8"	142	1	68	75	6479	7634
40STD-1420WDDL4	839	238	322	460		268	268	5"*2	200	1	56	8"	166	1	73	75	7029	7887
40STD-1580WDDL4	902	257	347	482		296	296	5"*2	215	1	58	8"	178	1	98	75	7535	8173
40STD-1660WDDL4	983	279	379	547		316	316	5"*2	234	1	63	8"	194	1	63	75	7788	8536
40STD-1860WDDL4	1109	315	427	618		354	354	6"*2	264	1	69	8"	219	1	69	75	8063	8921
40STD-2180WDDL4	1427	406	534	691		436	436	6"*2	337	1	72	8"	282	1	72	75	9900	11176
40STD-2560WDDL4	1601	455	597	841		512	512	8"*2	378	1	75	10"	316	1	75	75	10670	12100
40STD-3040WDDL4	1857	528	689	980		584	584	8"*2	438	1	80	10"	367	1	80	75	11330	12760
40STD-4560WDTL4	2786	792	1033	1470		876	876	8"*3	657	1	92	10"	551	1	97	75	15400	16720

Note:

- Nominal cooling capacity reference: evaporator inlet and outlet water temperature -10° C / -15° C, condenser inlet and outlet water temperature 30° C / 35° C; fouling factor 0.018 m² • ° C / kW;
- Chilled water temperature range: -20° C ~ -5° C ;
- Cooling water temperature range: 15° C ~ 40° C ;
- Specifications and dimensions are subject to improvement without notice.

Water-cooled low temperature chiller parameters / 60Hz (continued)

PAC Low Temperature / Glycol Chiller

Water-cooled low temperature chiller parameter (-20°C ~ -5°C)

Refrigerant: R404A Power supply: 460V-3N-60Hz

Model	Nominal cooling capacity		Compressor Input Power kW	Unit operating current A	Capacity control %	Refrigerant charge kg	Condenser				Evaporator				Operating sound level dB(A)	Shipping weight kg	Operating weight kg		
	kW	USRT					Condenser Inlet outlet pipe diameter in	Chilled Water flowm ³ /h	Water Side Max. Pressure Mpa	Water pressure drop KPa	condenser Inlet outlet pipe diameter in	20% ethylene glycol solution flow	Water Side Max. Pressure Mpa	Water pressure drop KPa					
40STD-S100WDSL4	56	16	31	43	0	18	2"	15	1	35	2"	11	1	26	73	1177	1287		
40STD-S140WDSL4	78	22	41	57		66	25	2-1/2"	20	1	40	2-1/2"	15	1	34	74	1210	1331	
40STD-S180WDSL4	102	29	51	72		100	32	3"	26	1	39	3"	20	1	38	75	1419	1562	
40STD-S230WDSL4	137	39	67	94	0	42	3"	35	1	46	3"	27	1	43	75	1595	1793		
40STD-S260WDSL4	147	42	73	102		66	46	3"	38	1	45	3"	29	1	55	75	1804	1980	
40STD-S300WDSL4	174	49	83	117		75	55	3"	44	1	44	3"	34	1	67	75	1958	2145	
40STD-S340WDSL4	204	58	96	138		84	62	4"	52	1	43	4"	40	1	74	75	2211	2409	
40STD-S370WDSL4	220	62	105	148		93	68	4"	56	1	43	4"	43	1	80	75	2343	2519	
40STD-S410WDSL4	239	68	115	165		102	75	4"	61	1	43	4"	47	1	77	75	2530	2761	
40STD-S470WDSL4	290	83	138	195		111	90	5"	74	1	44	4"	57	1	52	75	2915	3223	
40STD-S550WDSL4	336	95	159	222		120	102	5"	85	1	44	5"	66	1	57	75	3080	3388	
40STD-S580WDSL4	364	103	170	239		129	110	5"	92	1	44	5"	72	1	76	75	3311	3630	
40STD-S620WDSL4	378	107	178	251		138	115	5"	96	1	50	5"	75	1	96	75	3410	3883	
40STD-S710WDSL4	440	125	203	285	0	134	5"	111	1	56	5"	87	1	48	75	3630	4092		
40STD-S790WDSL4	474	135	219	303		143	148	5"	119	1	58	5"	94	1	70	75	3894	4477	
40STD-S830WDSL4	515	146	239	307		152	158	5"	130	1	59	5"	102	1	84	75	4202	4752	
40STD-S930WDSL4	581	165	270	390		161	177	6"	146	1	61	5"	115	1	87	75	4400	5027	
40STD-S1090WDSL4	749	213	337	433		170	218	6"	187	1	63	8"	148	1	90	75	4752	5038	
40STD-S1280WDSL4	840	239	376	525		179	256	8"	209	1	72	8"	166	1	92	75	5038	5698	
40STD-S1520WDSL4	975	277	434	619		188	292	8"	242	1	76	8"	193	1	95	75	5445	6105	
40STD-S200WDDL4	112	32	61	86		0	36	3"	30	1	38	3"	22	1	38	75	1914	2387	
40STD-S460WDDL4	273	78	134	188			35	84	3"	70	1	41	5"	54	1	51	75	2948	3828
40STD-S520WDDL4	294	83	147	205			44	92	5"	76	1	42	5"	58	1	46	75	3311	4312
40STD-S680WDDL4	408	116	193	275	53		124	5"	103	1	42	5"	81	1	54	75	4026	5236	
40STD-S1020WDDL4	607	173	282	395	62		188	4"*2	153	1	43	6"	120	1	58	75	5016	6358	
40STD-S1100WDDL4	671	191	318	444	71		204	5"*2	170	1	44	6"	133	1	35	75	5434	6886	
40STD-S1160WDDL4	727	207	340	477	80		220	5"*2	184	1	47	8"	144	1	38	75	5885	7370	
40STD-S1240WDDL4	755	215	356	502	89		230	5"*2	191	1	50	8"	149	1	68	75	6479	7634	
40STD-S1420WDDL4	880	250	406	570	98		268	5"*2	221	1	56	8"	174	1	73	75	7029	7887	
40STD-S1580WDDL4	947	269	438	606	107		296	5"*2	238	1	58	8"	187	1	98	75	7535	8173	
40STD-S1660WDDL4	1030	293	470	680	0	316	5"*2	258	1	63	8"	204	1	63	75	7788	8536		
40STD-S1860WDDL4	1162	330	540	780		325	354	6"*2	293	1	69	8"	230	1	69	75	8063	8921	
40STD-S2180WDDL4	1498	426	674	866		334	436	6"*2	374	1	72	8"	296	1	72	75	9900	11176	
40STD-S2560WDDL4	1681	478	752	1049		343	512	8"*2	419	1	75	10"	332	1	75	75	10670	12100	
40STD-S3040WDDL4	1951	555	869	1237		352	584	8"*2	485	1	80	10"	386	1	80	75	11330	12760	
40STD-S4560WDTL4	2926	832	1304	1856		361	876	8"*3	727	1	92	10"	578	1	97	75	15400	16720	

Note:

- Nominal cooling capacity reference: evaporator inlet and outlet water temperature -10° C / -15° C, condenser inlet and outlet water temperature 30° C / 35° C; fouling factor 0.018 m² • ° C / kW;
- Chilled water temperature range: -20° C ~ -5° C;
- Cooling water temperature range: 15° C ~ 40° C;
- Specifications and dimensions are subject to improvement without notice.

Water-cooled low temperature chiller parameters / 60Hz (continued)

PAC Low Temperature / Glycol Chiller

Water-cooled low temperature chiller parameter (-35°C ~ -20°C)

Refrigerant: R22 Power supply: 460V-3N-60Hz

Model	Nominal cooling capacity		Compressor input Power kW	Unit operating current A	Capacity control %	Refrigerant charge kg	Condenser				Evaporator				Operating sound level dB(A)	Shipping weight kg	Operating weight kg
	kW	USRT					Condenser Inlet outlet pipe diameter in	Chilled Water flow m ³ /h	Water Side Max. Pressure Mpa	Water pressure drop KPa	condenser Inlet outlet pipe diameter in	55% ethylene glycol solution flow	Water Side Max. Pressure Mpa	Water pressure drop KPa			
40STD-100WDSC4	22	6	21	28	0	18	2"	7	1	35	2"	5	1	27	75	1210	1320
40STD-140WDSC4	31	9	28	38	66	25	2-1/2"	10	1	40	2-1/2"	7	1	34	75	1276	1397
40STD-180WDSC4	40	11	35	50	100	32	3"	13	1	39	3"	9	1	39	75	1474	1661
40STD-230WDSC4	54	15	46	63		42	3"	17	1	46	3"	12	1	43	75	1650	1848
40STD-260WDSC4	58	16	50	68		46	3"	19	1	45	3"	13	1	56	75	1837	2013
40STD-300WDSC4	68	19	58	79		55	3"	22	1	44	3"	15	1	27	75	2002	2189
40STD-340WDSC4	80	23	67	92		62	4"	25	1	43	4"	18	1	26	75	2277	2486
40STD-370WDSC4	87	25	80	100		68	4"	29	1	43	4"	19	1	82	75	2409	2585
40STD-410WDSC4	94	27	82	113		75	4"	30	1	44	4"	21	1	53	75	2618	2849
40STD-470WDSC4	114	32	96	131		90	5"	36	1	90	4"	25	1	44	75	2992	3300
40STD-550WDSC4	132	38	111	150	0	102	5"	42	1	44	5"	29	1	58	75	3113	3432
40STD-580WDSC4	143	41	119	161	50	110	5"	45	1	44	5"	32	1	78	75	3366	3685
40STD-620WDSC4	149	42	124	168	75	115	5"	47	1	50	5"	33	1	98	75	3476	3938
40STD-710WDSC4	173	49	142	197	100	134	5"	54	1	56	5"	38	1	49	75	3685	4147
40STD-790WDSC4	186	53	153	204		148	5"	58	1	58	5"	41	1	71	75	3949	4532
40STD-830WDSC4	203	58	167	233		158	5"	64	1	59	5"	45	1	85	75	4257	4807
40STD-930WDSC4	229	65	189	261		177	6"	72	1	61	5"	51	1	88	75	4455	5082
40STD-1090WDSC4	295	84	240	295		218	6"	92	1	63	8"	65	1	91	75	4818	5456
40STD-1280WDSC4	331	94	268	365		256	8"	103	1	72	8"	73	1	94	75	5104	5764
40STD-1520WDSC4	384	109	309	423		292	8"	119	1	76	8"	85	1	97	75	5522	6171
40STD-200WDDC4	44	13	41	57	0	36	3"	15	1	36	3"	10	1	38	75	2002	2475
40STD-460WDDC4	108	31	93	126	25	84	4"	34	1	84	5"	24	1	52	75	3036	3916
40STD-520WDDC4	116	33	101	136	33.5	92	5"	37	1	92	5"	26	1	42	75	3410	4411
40STD-680WDDC4	161	46	134	185	50	124	5"	51	1	42	5"	35	1	55	75	4136	5346
40STD-1020WDDC4	239	68	207	272	62.5	188	4"*2	60	1	43	6"	53	1	59	75	5115	6457
40STD-1100WDDC4	264	75	222	301	75	204	5"*2	84	1	44	6"	58	1	65	75	5533	6985
40STD-1160WDDC4	286	81	238	321	87.5	220	5"*2	90	1	47	8"	63	1	64	75	5984	7469
40STD-1240WDDC4	297	84	248	336	100	230	5"*2	94	1	50	8"	66	1	69	75	6622	7766
40STD-1420WDDC4	346	98	285	393		268	5"*2	109	1	56	8"	76	1	75	75	7161	8019
40STD-1580WDDC4	373	106	307	408		296	5"*2	117	1	58	8"	82	1	97	75	7667	8305
40STD-1660WDDC4	406	115	335	467		316	5"*2	127	1	63	8"	90	1	93	75	7920	8668
40STD-1860WDDC4	458	130	378	522		354	6"*2	144	1	69	8"	101	1	90	75	8195	9053
40STD-2180WDDC4	590	168	480	590		436	6"*2	184	1	72	8"	130	1	87	75	10032	11308
40STD-2560WDDC4	662	188	535	732		512	8"*2	206	1	75	10"	146	1	96	75	10802	12265
40STD-3040WDDC4	768	218	618	846		584	8"*2	238	1	80	10"	169	1	104	75	11495	12892
40STD-4560WDTC4	1152	327	927	1270		876	8"*3	357	1	92	10"	254	1	105	75	15400	16720

Note:

1. Nominal cooling capacity reference: evaporator inlet and outlet water temperature -30° C / -35° C, condenser inlet and outlet water temperature 30° C / 35° C; fouling factor 0.018 m² • ° C / kW;
2. Chilled water temperature range: -35° C ~ -20° C;
3. Cooling water temperature range: 15° C ~ 40° C
4. Specifications and dimensions are subject to improvement without notice.

Water-cooled low temperature chiller parameters / 60Hz (continued)

PAC Low Temperature / Glycol Chiller

Water-cooled low temperature chiller parameter(-35°C ~ -20°C)

Refrigerant: R404A Power supply: 460V-3N-60Hz

Model	Nominal cooling capacity		Compressor Input Power kW	Unit operating current A	Capacity control %	Refrigerant charge kg	Condenser				Evaporator				Operating sound level dB(A)	Shipping weight kg	Operating weight kg
	kW	USRT					Condenser Inlet outlet pipe diameter in	Chilled Water flowm ³ /h	Water Side Max. Pressure Mpa	Water pressure drop KPa	condenser Inlet outlet pipe diameter in	55% ethylene glycol solution flow	Water Side Max. Pressure Mpa	Water pressure drop KPa			
40STD-S100WDSC4	21	6	23	33	0 66 100	18	2"	8	1	35	2"	5	1	27	75	1210	1320
40STD-S140WDSC4	30	8	31	44		25	2-1/2"	10	1	40	2-1/2"	7	1	34	75	1276	1397
40STD-S180WDSC4	39	11	39	57		32	3"	13	1	39	3"	9	1	39	75	1474	1661
40STD-S230WDSC4	52	15	52	73		42	3"	18	1	46	3"	11	1	43	75	1650	1848
40STD-S260WDSC4	56	16	56	79		46	3"	19	1	45	3"	12	1	56	75	1837	2013
40STD-S300WDSC4	66	19	65	93		55	3"	22	1	44	3"	15	1	27	75	2002	2189
40STD-S340WDSC4	77	22	75	109		62	4"	26	1	43	4"	17	1	26	75	2277	2486
40STD-S370WDSC4	83	24	82	118		68	4"	28	1	43	4"	18	1	82	75	2409	2585
40STD-S410WDSC4	90	26	89	130		75	4"	31	1	44	4"	20	1	53	75	2618	2849
40STD-S470WDSC4	110	31	108	152		90	5"	37	1	90	4"	24	1	44	75	2992	3300
40STD-S550WDSC4	127	36	124	175	0 50 75 100	102	5"	43	1	44	5"	28	1	58	75	3113	3432
40STD-S580WDSC4	138	39	133	187		110	5"	47	1	44	5"	30	1	78	75	3366	3685
40STD-S620WDSC4	143	41	139	199		115	5"	49	1	50	5"	32	1	98	75	3476	3938
40STD-S710WDSC4	167	47	160	229		134	5"	56	1	56	5"	37	1	49	75	3685	4147
40STD-S790WDSC4	179	51	173	240		148	5"	61	1	58	5"	40	1	71	75	3949	4532
40STD-S830WDSC4	195	55	188	272		158	5"	66	1	59	5"	43	1	85	75	4257	4807
40STD-S930WDSC4	220	63	212	307		177	6"	74	1	61	5"	49	1	88	75	4455	5082
40STD-S1090WDSC4	284	81	268	344		218	6"	95	1	63	8"	63	1	91	75	4818	5456
40STD-S1280WDSC4	319	91	300	423		256	8"	106	1	72	8"	70	1	94	75	5104	5764
40STD-S1520WDSC4	373	106	372	494		292	8"	128	1	76	8"	82	1	97	75	5522	6171
40STD-S200WDDC4	42	12	46	65	0 25 33.5 50 62.5 75 87.5 100	36	3"	15	1	36	3"	9	1	38	75	2002	2475
40STD-S460WDDC4	104	29	104	147		84	4"	36	1	84	5"	23	1	52	75	3036	3916
40STD-S520WDDC4	111	32	113	159		92	5"	38	1	92	5"	25	1	42	75	3410	4411
40STD-S680WDDC4	155	44	151	218		124	5"	52	1	42	5"	34	1	55	75	4136	5346
40STD-S1020WDDC4	230	65	222	316		188	4**2	60	1	43	6"	51	1	59	75	5115	6457
40STD-S1100WDDC4	254	72	248	350		204	5**2	86	1	44	6"	56	1	65	75	5533	6985
40STD-S1160WDDC4	276	78	267	375		220	5**2	93	1	47	8"	61	1	64	75	5984	7469
40STD-S1240WDDC4	286	81	279	397		230	5**2	97	1	50	8"	63	1	69	75	6622	7766
40STD-S1420WDDC4	333	95	320	458		268	5**2	112	1	56	8"	74	1	75	75	7161	8019
40STD-S1580WDDC4	359	102	345	480		296	5**2	121	1	58	8"	79	1	97	75	7667	8305
40STD-S1660WDDC4	390	111	376	543	316	5**2	132	1	63	8"	86	1	93	75	7920	8668	
40STD-S1860WDDC4	440	125	425	614	354	6**2	149	1	69	8"	97	1	90	75	8195	9053	
40STD-S2180WDDC4	568	161	537	688	436	6**2	190	1	72	8"	125	1	87	75	10032	11308	
40STD-S2560WDDC4	637	181	601	846	512	8**2	213	1	75	10"	141	1	96	75	10802	12265	
40STD-S3040WDDC4	745	212	743	988	584	8**2	256	1	80	10"	165	1	104	75	11495	12892	
40STD-S4560WDTC4	1118	318	1115	1482	876	8**3	384	1	92	10"	247	1	105	75	15400	16720	

Note:

- Nominal cooling capacity reference: evaporator inlet and outlet water temperature -30° C / -35° C, condenser inlet and outlet water temperature 30° C / 35° C; fouling factor 0.018 m² • ° C / kW;
- Chilled water temperature range: -35° C ~ -20° C
- Cooling water temperature range: 15° C ~ 40° C
- Specifications and dimensions are subject to improvement without notice.

Chiller Dimension

40STD series water-cooled low temperature chiller dimension drawing (-5°C ~ 10°C)

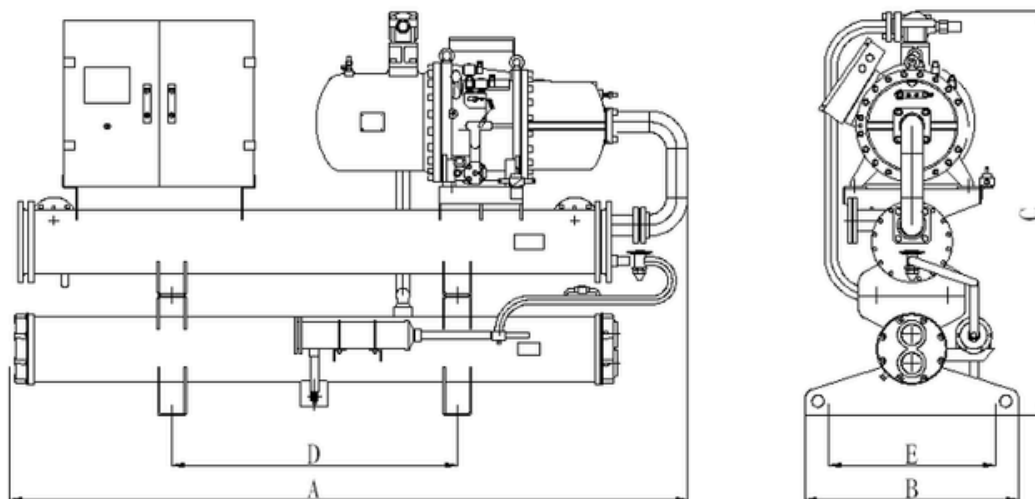

Model	A	B	C	D	E
40STD-(S)100WDSH4	2200	800	1500	1100	600
40STD-(S)140WDSH4	2250	800	1550	1100	600
40STD-(S)180WDSH4	2350	800	1650	1200	600
40STD-(S)230WDSH4	2550	900	1800	1200	700
40STD-(S)260WDSH4	2600	900	1800	1200	700
40STD-(S)300WDSH4	2900	900	1800	1200	700
40STD-(S)340WDSH4	2900	900	1850	1200	700
40STD-(S)370WDSH4	2900	900	1850	1200	700
40STD-(S)410WDSH4	2950	900	1950	1200	700
40STD-(S)470WDSH4	3000	1500	1500	2200	920
40STD-(S)550WDSH4	3000	1500	1600	2200	920
40STD-(S)580WDSH4	3600	1500	1600	2200	920
40STD-(S)620WDSH4	3600	1500	1650	2200	920
40STD-(S)710WDSH4	3600	1500	1650	2800	950
40STD-(S)790WDSH4	3600	1500	1700	2800	950
40STD-(S)830WDSH4	3600	1500	1700	2800	950
40STD-(S)930WDSH4	3600	1500	1700	2800	950
40STD-(S)1090WDSH4	4600	1850	1900	3000	1000
40STD-(S)1280WDSH4	4600	1900	2000	3000	1000
40STD-(S)1520WDSH4	4600	1900	2000	3000	1000

Chiller Dimension (continued)

40STD series water-cooled low temperature dimension drawing (-5°C ~ 10°C)

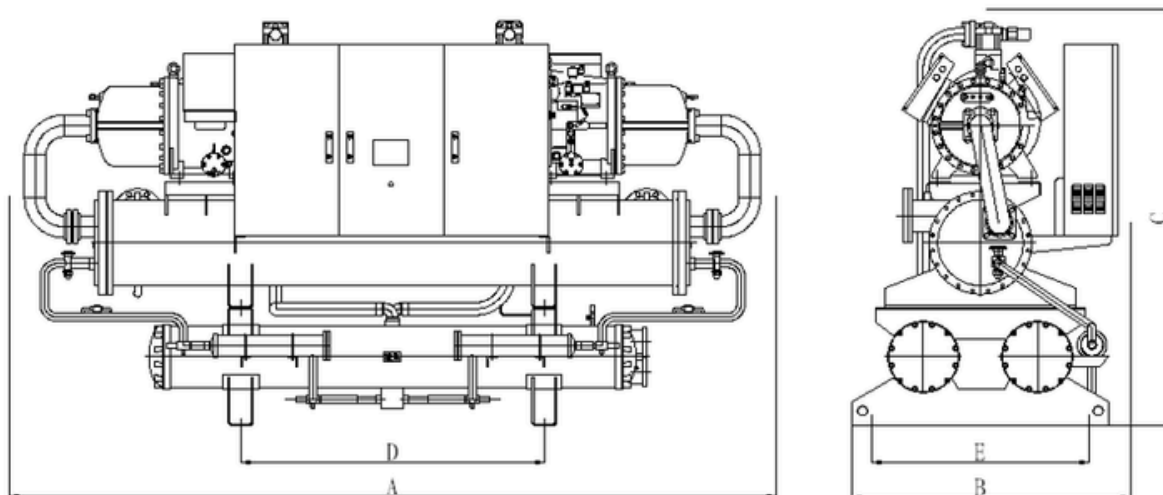

Model	A	B	C	D	E
40STD-(S)200WDDH4	2650	1000	1650	1200	700
40STD-(S)460WDDH4	3200	1100	1750	1600	700
40STD-(S)520WDDH4	3300	1100	1950	1600	700
40STD-(S)680WDDH4	3400	1250	2050	1600	1150
40STD-(S)1020WDDH4	4100	1450	2200	1600	1250
40STD-(S)1100WDDH4	3900	1650	2300	1600	1350
40STD-(S)1160WDDH4	4500	1750	2450	1600	1350
40STD-(S)1240WDDH4	4500	1750	2500	1600	1350
40STD-(S)1420WDDH4	4600	1850	2500	2400	1690
40STD-(S)1580WDDH4	4600	1850	2600	2400	1690
40STD-(S)1660WDDH4	4600	1850	2600	2400	1690
40STD-(S)1860WDDH4	3800	1850	2600	2600	1690
40STD-(S)2180WDDH4	4700	2250	2800	2800	2000
40STD-(S)2560WDDH4	5200	2250	2800	2800	2200
40STD-(S)3040WDDH4	5200	2250	2800	2800	2200
40STD-(S)4560WDDH4	6000	3000	2800	2800	2500

Chiller Dimension (continued)

PAC Low Temperature / Glycol Chiller

40STD series water-cooled low temperature dimension drawing (-20°C ~ -5°C)

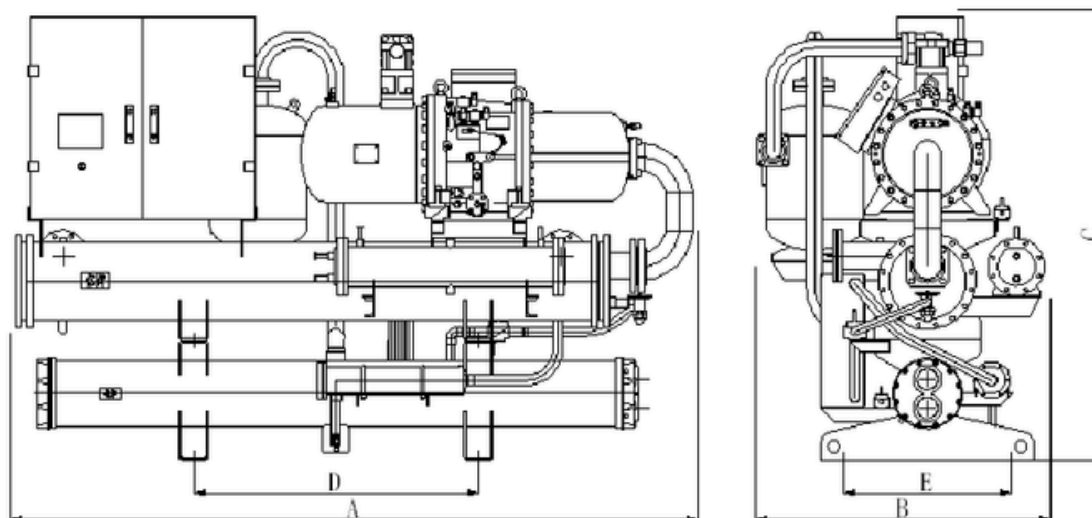

Model	A	B	C	D	E
40STD-(S)100WDSL4	2200	900	1500	1100	600
40STD-(S)140WDSL4	2250	950	1550	1100	600
40STD-(S)180WDSL4	2350	1000	1650	1200	600
40STD-(S)230WDSL4	2550	1000	1800	1200	700
40STD-(S)260WDSL4	2600	1000	1800	1200	700
40STD-(S)300WDSL4	2900	1000	1800	1200	700
40STD-(S)340WDSL4	2900	1250	1850	1200	700
40STD-(S)370WDSL4	2900	1450	1850	1200	700
40STD-(S)410WDSL4	2950	1450	1950	1200	700
40STD-(S)470WDSL4	3000	1700	1500	2200	780
40STD-(S)550WDSL4	3000	1700	1600	2200	920
40STD-(S)580WDSL4	3600	1700	1600	2200	920
40STD-(S)620WDSL4	3600	1700	1650	2200	920
40STD-(S)710WDSL4	3600	1750	1650	2800	950
40STD-(S)790WDSL4	3600	1750	1700	2800	950
40STD-(S)830WDSL4	3600	1750	1700	2800	950
40STD-(S)930WDSL4	3600	1850	1700	2800	1000
40STD-(S)1090WDSL4	4600	1850	1900	3000	1000
40STD-(S)1280WDSL4	4600	1900	2000	3000	1000
40STD-(S)1520WDSL4	4600	1900	2000	3000	1000

Chiller Dimension (continued)

PAC Low Temperature / Glycol Chiller

40STD series water-cooled low temperature dimension drawing (-20°C ~ -5°C)

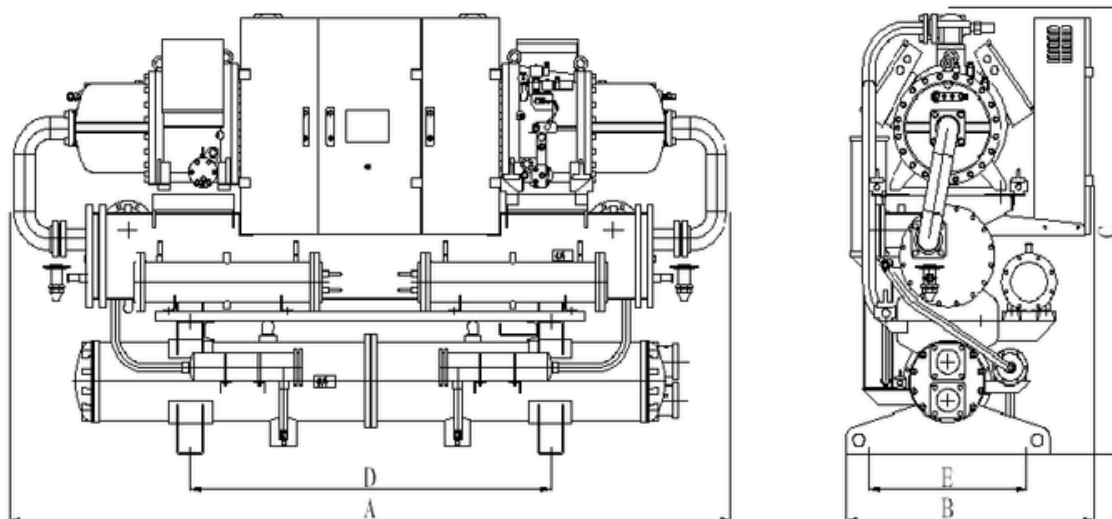

Model	A	B	C	D	E
40STD-(S)200WDDL4	2650	1300	1650	1200	700
40STD-(S)460WDDL4	3200	1350	1750	1600	700
40STD-(S)520WDDL4	3300	1400	1950	1600	700
40STD-(S)680WDDL4	3400	1450	2050	1600	900
40STD-(S)1020WDDL4	4100	2050	2200	1600	1500
40STD-(S)1100WDDL4	3900	2050	2300	1600	1500
40STD-(S)1160WDDL4	4500	2050	2450	1600	1500
40STD-(S)1240WDDL4	4500	2050	2500	1600	1500
40STD-(S)1420WDDL4	4600	2100	2550	1600	1690
40STD-(S)1580WDDL4	4600	2100	2600	2600	1690
40STD-(S)1660WDDL4	4600	2100	2600	2600	1690
40STD-(S)1860WDDL4	3800	2250	2600	2600	1690
40STD-(S)2180WDDL4	4700	2250	2800	2800	2000
40STD-(S)2560WDDL4	5200	2250	2800	2800	2200
40STD-(S)3040WDDL4	5200	2250	2800	2800	2200
40STD-(S)4560WDDL4	6000	3000	2800	2800	2500

Chiller Dimension (continued)

PAC Low Temperature / Glycol Chiller

40STD series water-cooled low temperature dimension drawing (-35°C ~ -20°C)

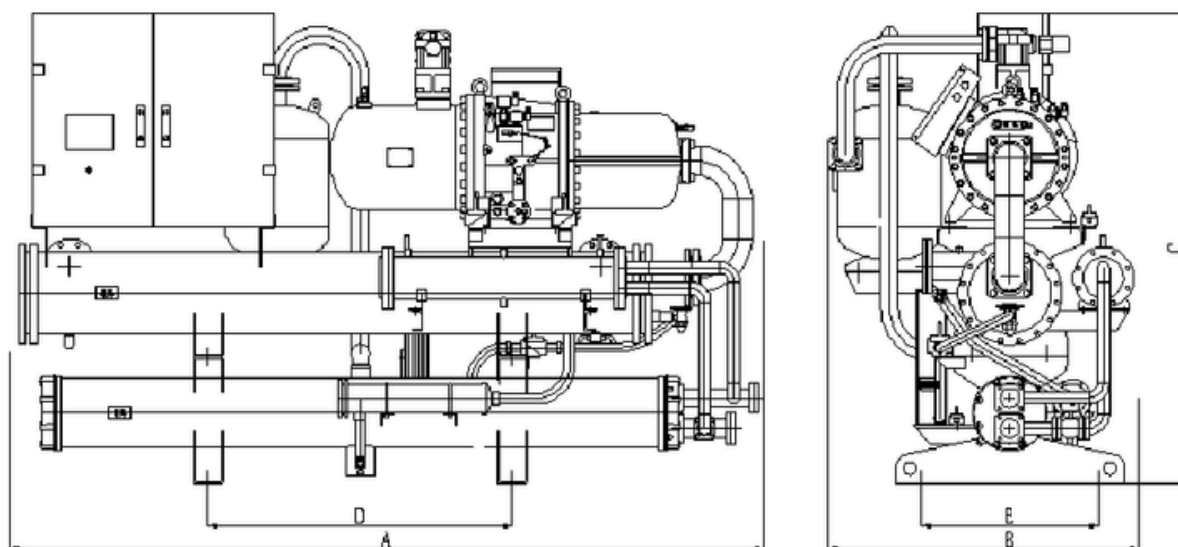

Model	A	B	C	D	E
40STD-(S)100WDC4	2200	900	1500	1100	600
40STD-(S)140WDC4	2250	950	1550	1100	600
40STD-(S)180WDSC4	2350	1000	1650	1200	600
40STD-(S)230WDSC4	2550	1000	1800	1200	700
40STD-(S)260WDSC4	2600	1000	1800	1200	700
40STD-(S)300WDSC4	2900	1000	1800	1200	700
40STD-(S)340WDSC4	2900	1250	1850	1200	700
40STD-(S)370WDSC4	2900	1450	1850	1200	700
40STD-(S)410WDSC4	2950	1450	1950	1200	700
40STD-(S)470WDSL4	3000	1700	1500	2200	780
40STD-(S)550WDSC4	3000	1700	1600	2200	920
40STD-(S)580WDSC4	3600	1700	1600	2200	920
40STD-(S)620WDSC4	3600	1700	1650	2200	920
40STD-(S)710WDSC4	3600	1750	1650	2800	950
40STD-(S)790WDSC4	3600	1750	1700	2800	950
40STD-(S)830WDSC4	3600	1750	1700	2800	950
40STD-(S)930WDSC4	3600	1850	1700	2800	1000
40STD-(S)1090WDSC4	4600	1850	1900	3000	1000
40STD-(S)1280WDSC4	4600	1900	2000	3000	1000
40STD-(S)1520WDSC4	4600	1900	2000	3000	1000

Chiller Dimension (continued)

PAC Low Temperature / Glycol Chiller

40STD series water-cooled low temperature dimension drawing (-35°C ~ -20°C)

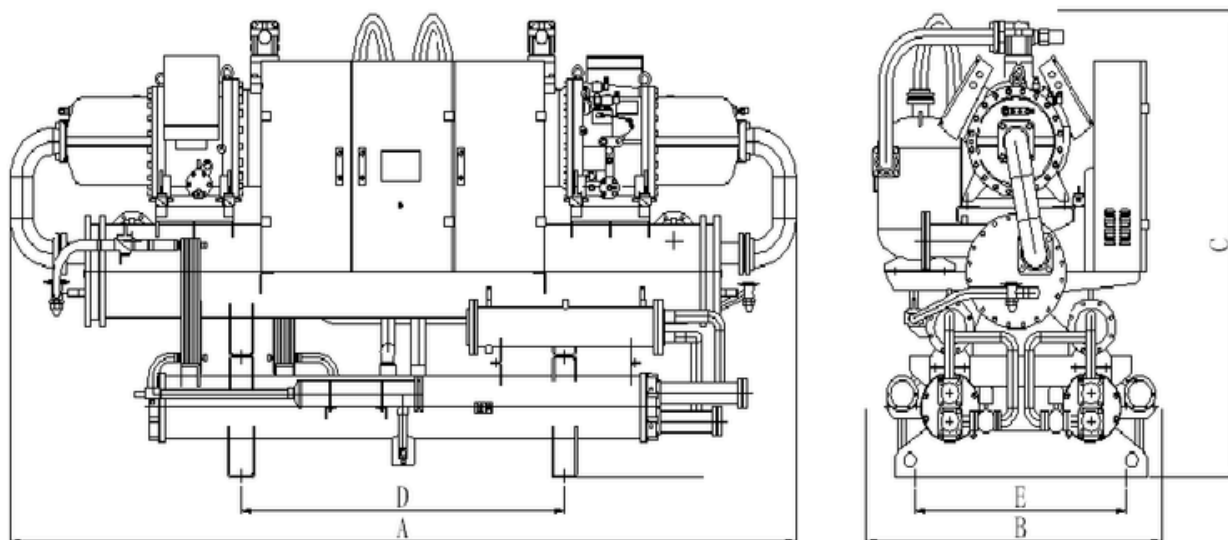

Model	A	B	C	D	E
40STD-(S)200WDDC4	2650	1300	1650	1600	700
40STD-(S)460WDDC4	3200	1350	1750	1600	700
40STD-(S)520WDDC4	3300	1400	1950	1600	700
40STD-(S)680WDDC4	3400	1450	2050	1600	1100
40STD-(S)1020WDDC4	4100	2050	2200	1600	1500
40STD-(S)1100WDDC4	3900	2050	2300	1600	1500
40STD-(S)1160WDDC4	4500	2050	2450	1600	1500
40STD-(S)1240WDDC4	4500	2050	2500	1600	1500
40STD-(S)1420WDDC4	4600	2100	2550	1600	1690
40STD-(S)1580WDDC4	4600	2100	2600	2600	1690
40STD-(S)1660WDDC4	4600	2100	2600	2600	1690
40STD-(S)1860WDDC4	3800	2250	2600	2600	1690
40STD-(S)2180WDDC4	4700	2250	2800	2800	2000
40STD-(S)2560WDDC4	5200	2250	2800	2800	2200
40STD-(S)3040WDDC4	5200	2250	2800	2800	2200
40STD-(S)4560WDDC4	6000	3000	2800	2800	2500

Foundation base drawing

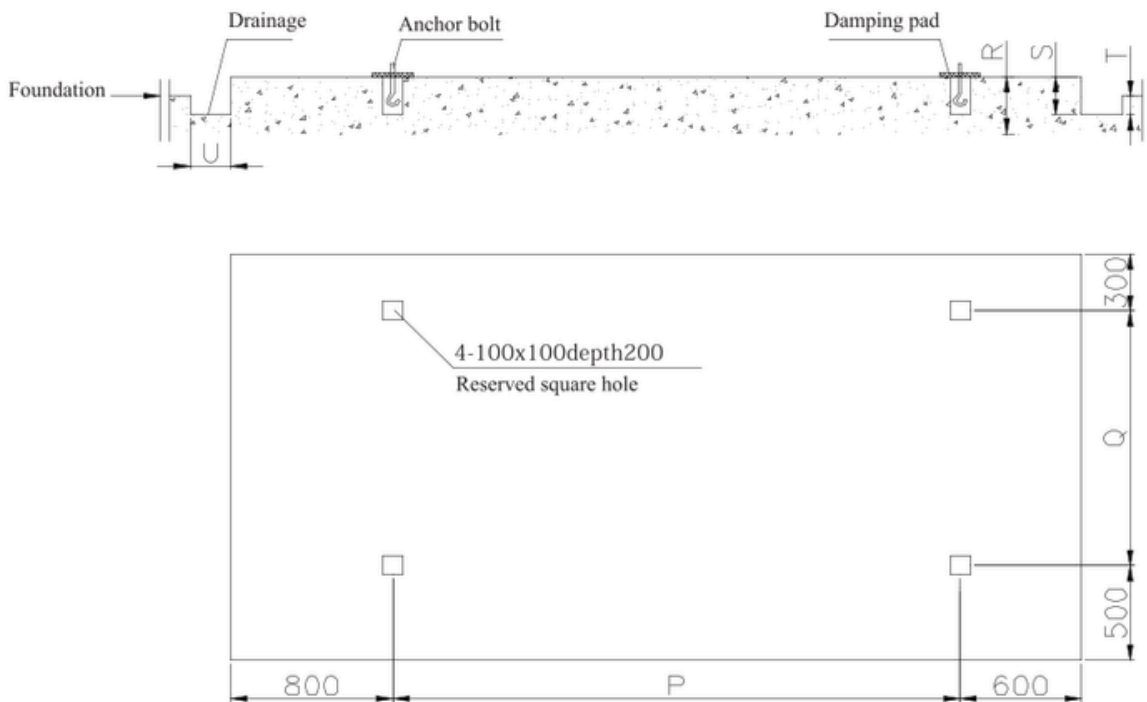

Air-cooled chiller foundation size

Model	P	Q	R	S	T	U
40STE-140ADSL4	1500	1100	300	200	100	200
40STE-200ADSL4	1800	2050	300	200	100	200
40STE-260ADSL4	1800	2050	300	200	100	200
40STE-300ADSL4	1800	2050	300	200	100	200
40STE-340ADSL4	1400	2050	300	200	100	200
40STE-370ADSL4	1400	2050	300	200	100	200
40STE-410ADSL4	1400	2050	300	200	100	200
40STE-460ADDL4	1800	2050	300	200	100	200
40STE-520ADDL4	1800	2050	300	200	100	200
40STE-600ADDL4	1800	2050	300	200	100	200
40STE-680ADDL4	3000	2050	300	200	100	200
40STE-740ADDL4	3000	2050	300	200	100	200

Water-cooled chiller foundation size

Model	P	Q	R	S	T	U
40STD-100WDSH(L)(C)4	1100	600	300	200	100	200
40STD-140WDSH(L)(C)4	1100	600	300	200	100	200
40STD-180WDSH(L)(C)4	1200	600	300	200	100	200
40STD-230WDSH(L)(C)4	1200	700	300	200	100	200
40STD-260WDSH(L)(C)4	1200	700	300	200	100	200
40STD-300WDSH(L)(C)4	1200	700	300	200	100	200
40STD-340WDSH(L)(C)4	1200	700	300	200	100	200
40STD-370WDSH(L)(C)4	1200	700	300	200	100	200
40STD-410WDSH(L)(C)4	1200	700	300	200	100	200
40STD-470WDSH(L)(C)4	2200	920	300	200	100	200
40STD-550WDSH(L)(C)4	2200	920	300	200	100	200
40STD-580WDSH(L)(C)4	2200	920	300	200	100	200
40STD-620WDSH(L)(C)4	2200	920	300	200	100	200
40STD-710WDSH(L)(C)4	2800	950	300	200	100	200
40STD-790WDSH(L)(C)4	2800	950	300	200	100	200
40STD-830WDSH(L)(C)4	2800	950	300	200	100	200
40STD-930WDSH(L)(C)4	2800	950	300	200	100	200
40STD-1090WDSH(L)(C)4	3000	1000	300	200	100	200
40STD-1280WDSH(L)(C)4	3000	1000	300	200	100	200
40STD-1520WDSH(L)(C)4	3000	1000	300	200	100	200
40STD-200WDDH(L)(C)4	1200	700	300	200	100	200
40STD-460WDDH(L)(C)4	1600	700	300	200	100	200
40STD-520WDDH(L)(C)4	1600	700	300	200	100	200
40STD-680WDDH(L)(C)4	1600	1150	300	200	100	200
40STD-1020WDDH(L)(C)4	1600	1500	300	200	100	200
40STD-1100WDDH(L)(C)4	1600	1500	300	200	100	200
40STD-1160WDDH(L)(C)4	1600	1500	300	200	100	200
40STD-1240WDDH(L)(C)4	1600	1500	300	200	100	200
40STD-1420WDDH(L)(C)4	2400	1690	300	200	100	200
40STD-1580WDDH(L)(C)4	2600	1690	300	200	100	200
40STD-1660WDDH(L)(C)4	2600	1690	300	200	100	200
40STD-1860WDDH(L)(C)4	2600	1690	300	200	100	200
40STD-2180WDDH(L)(C)4	2800	2000	300	200	100	200
40STD-2560WDDH(L)(C)4	2800	2200	300	200	100	200
40STD-3040WDDH(L)(C)4	2800	2200	300	200	100	200
40STD-4560WDDH(L)(C)4	2800	2500	300	200	100	200

Water connection diagram / wiring diagram

PAC Low Temperature / Glycol Chiller

Water connection diagram

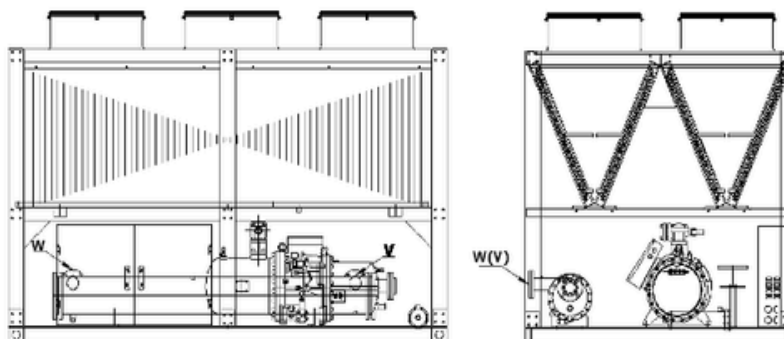

Code	W	V
Interface definition	Evaporator water inlet	Evaporator water outlet

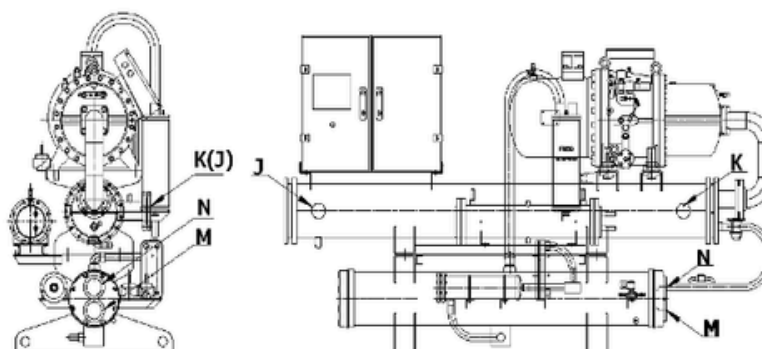

Code	J	K	M	N
Interface definition	Evaporator water inlet	Evaporator water outlet	Condenser water inlet	Condenser water outlet

Wiring diagram

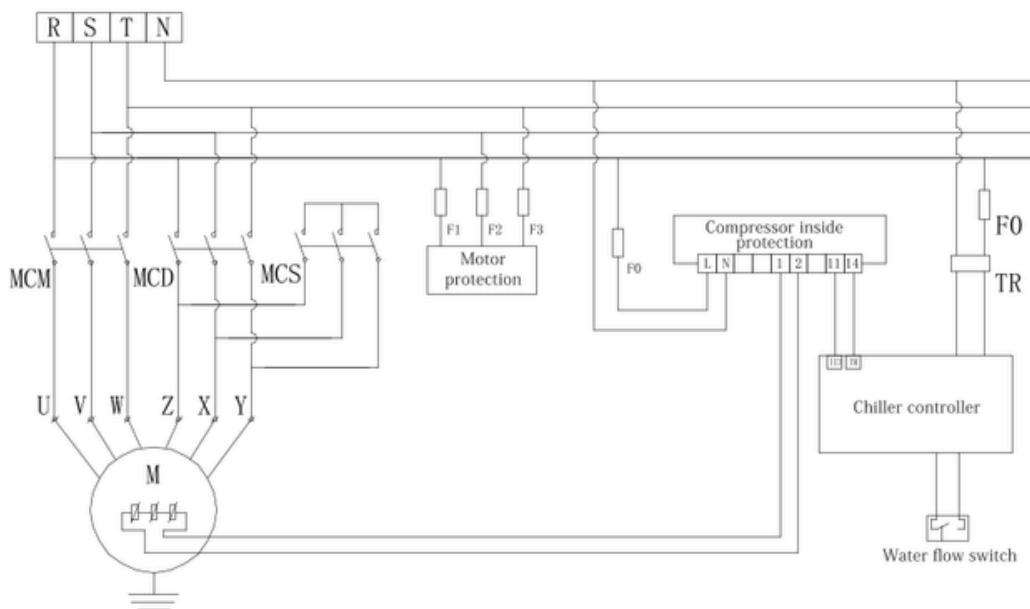

PAC Corporation (Thailand) Co., Ltd.

Well-being

ENERGY SAVING SOLUTIONS

FOR SUSTAINABLE LIFE
& BUSINESS

บริษัท แพค คอร์ปอเรชั่น (ประเทศไทย) จำกัด

สำนักงานใหญ่

12/2 วิชั่น บิสิเนส พาร์ค เฟส 2 ซอยรามอินทรา 55/8 ถนนรามอินทรา แขวงท่าแร้ง

เขตบางเขน กรุงเทพฯ 10230

เบอร์โทรศัพท์

02-347-0447

เบอร์โทรสาร

02-347-0448

ฝ่ายวิศวกรรมและบริการ

258-268 ซอยรามอินทรา 65 ถนนรามอินทรา แขวงท่าแร้ง เขตบางเขน กรุงเทพฯ 10230

เบอร์โทรศัพท์

02-945-8361-3

เบอร์โทรสาร

02-945-8316

Hotline ฝ่ายบริการ 095-775-9278

Line Official Account @pacservice

อีเมล

info@pac.co.th

facebook

www.facebook.com/PACSolutions